

# MicroGenius<sup>®</sup> 2

## *Genset, Marine & Stationary Battery Charger*



## **Installation & Operation Manual**

180W: 12V, 10A; 24V, 6A

300W: 12V, 12A; 24V, 10A

450W: 12/24V, 15A

---

SENS Part Number: 101324  
Document Revision: P  
DCN Number: 107748  
Date: December 2, 2019

PATENTED US 9,270,140; 9,385,556; 9,413,186; 9,509,164;  
9,466,995; 9,948,125

Installation or service questions?  
Call SENS between 8 a.m. and 5 p.m. (Mountain Time),  
Monday through Friday, or visit our website.



1840 Industrial Circle  
Longmont, CO 80501  
Phone: 303.678.7500  
800.742.2326  
Fax: 303.678.7504  
Email: [service@sens-usa.com](mailto:service@sens-usa.com)  
Web: [www.sens-usa.com](http://www.sens-usa.com)

## TABLE OF CONTENTS

<b>1</b>	<b>IMPORTANT SAFETY INSTRUCTIONS/INSTRUCTIONS IMPORTANTES CONCERNANT LA SÉCURITÉ</b> .....	<b>3</b>
<b>2</b>	<b>MODEL NUMBER BREAKOUT</b> .....	<b>5</b>
<b>3</b>	<b>PERFORMANCE SPECIFICATIONS</b> .....	<b>5</b>
<b>4</b>	<b>SYSTEM OVERVIEW</b> .....	<b>10</b>
<b>5</b>	<b>MOUNTING INSTRUCTIONS</b> .....	<b>11</b>
5.1.	Mounting Location .....	11
5.2.	Mounting Instructions .....	12
<b>6</b>	<b>CHARGER SETUP</b> .....	<b>13</b>
6.1.	Factory Jumper Configuration .....	13
6.2.	Standard Jumper Configuration .....	14
6.3.	Keypad Configuration— <i>Optional</i> .....	16
6.4.	Ultracapacitor Mode Setup .....	16
6.5.	Program Mode .....	17
6.6.	Load Share Charger Setup .....	17
6.7.	SAE J1939 Communications Setup (CANbus).....	17
6.8.	Modbus Communications Setup .....	18
<b>7</b>	<b>WIRING</b> .....	<b>19</b>
7.1.	Wire Ratings and Sizes.....	20
7.2.	Grounding Instructions and Connection.....	21
7.3.	DC Connection.....	21
7.4.	AC Connection.....	21
7.5.	Alarm Connections— <i>Optional</i> .....	21
7.6.	Remote Temperature Sensor Connection— <i>Optional</i> .....	23
7.7.	J1939/Modbus Communications Connection.....	23
7.8.	Load Share Connection— <i>Optional</i> .....	24
7.9.	Remote Alarm/Communications Panel Accessory Connection— <i>Optional</i> .....	24
7.10.	Verify Connections .....	25
<b>8</b>	<b>POWER ON/POWER OFF PROCEDURE</b> .....	<b>25</b>
8.1.	Connect Battery .....	25
8.2.	Apply AC Input Voltage.....	25
8.3.	Power Off .....	25
<b>9</b>	<b>ALARMS, LEDS AND DISPLAY</b> .....	<b>25</b>
9.1.	LED Indicators.....	25
9.2.	Individual Alarm Relay Contacts— <i>Optional</i> .....	26
9.3.	LCD Panel— <i>Optional</i> .....	26
9.4.	Alarm Definitions.....	26
<b>10</b>	<b>OPERATION</b> .....	<b>34</b>
10.1.	Charging Algorithms .....	34
10.2.	Float Mode .....	34
10.3.	Dynamic Boost™ Mode .....	35
10.4.	HELIX Mode .....	36
10.5.	Ultracapacitor Mode .....	37
10.6.	Charging Low or Zero-volt Batteries.....	37
10.7.	Commissioning Batteries.....	37
10.8.	Battery Check .....	37
10.9.	Keypad Operation .....	38
10.10.	Program Mode .....	41
10.11.	Temperature Compensation .....	42
10.12.	Load Share Charger Operation .....	42
10.13.	Remote Alarm/Communications Panel Accessory.....	43
<b>11</b>	<b>J1939 COMMUNICATIONS</b> .....	<b>43</b>
11.1.	J1939 Data Messages .....	43
<b>12</b>	<b>MODBUS COMMUNICATIONS</b> .....	<b>44</b>
12.1.	Modbus Default Settings.....	44
12.2.	Modbus Holding Registers.....	44
12.3.	Status Definition.....	47
12.4.	Alarm Bit Definition .....	47
12.5.	Extended Status Bit Definition.....	48
12.6.	Writable Control Flags (Coils) .....	49
<b>13</b>	<b>TROUBLESHOOTING/ERROR CODES</b> .....	<b>50</b>
13.1.	Configuration Error Codes .....	50
13.2.	Troubleshooting .....	52
<b>14</b>	<b>GLOSSARY</b> .....	<b>57</b>

## 1 IMPORTANT SAFETY INSTRUCTIONS/INSTRUCTIONS IMPORTANTES CONCERNANT LA SÉCURITÉ

---

- 1.1. **SAVE THESE INSTRUCTIONS** – This manual contains important safety and operating instructions for MicroGenius® 2 battery chargers.

*Conserver ces instructions. Ce manuel contient des instructions importantes concernant la sécurité et le fonctionnement.*

- 1.2. Do not expose open-frame charger to rain or snow.
- 1.3. Use of an attachment not recommended or sold by the battery charger manufacturer may result in a risk of fire, electric shock, or injury to persons.
- 1.4. **This charger is intended for commercial and industrial use. ONLY TRAINED AND QUALIFIED PERSONNEL MAY INSTALL AND SERVICE THIS UNIT.**
- 1.5. To reduce risk of damage to electric plug and cord (if optional power cord is included), pull by plug rather than cord when disconnecting charger.
- 1.6. Do not operate charger with damaged cord or plug – replace the cord or plug immediately.
- 1.7. Do not operate charger if it has received a sharp blow, been dropped, or otherwise damaged in any way; shut off power at the branch circuit protectors and have the unit serviced or replaced by qualified personnel.
- 1.8. To reduce risk of electric shock, disconnect the branch circuit feeding the charger before attempting any maintenance or cleaning. Turning off controls will not reduce this risk.
- 1.9. External connections to charger shall comply with the United States Coast Guard electrical regulations (33CFR183 SUB PART I).

### 1.10. WARNING – RISK OF EXPLOSIVE GASES

**1.10.1. WORKING IN THE VICINITY OF A LEAD-ACID OR NICKEL-CADMIUM BATTERY IS DANGEROUS. STORAGE BATTERIES GENERATE EXPLOSIVE GASES DURING NORMAL BATTERY OPERATION. FOR THIS REASON, IT IS OF UTMOST IMPORTANCE THAT YOU READ THIS MANUAL AND FOLLOW THE INSTRUCTIONS EACH TIME YOU USE THE CHARGER.**

***IL EST DANGEREUX DE TRAVAILLER A PROXIMITÉ D'UNE BATTERIE AU PLOMB. LES BATTERIES PRODUISENT DES GAZ EXPLOSIFS EN SERVICE NORMAL. IL EST AUSSI IMPORTANT DE TOUJOURS RELIRE LES INSTRUCTIONS AVANT D'UTILISER LE CHARGEUR ET DE LES SUIVRE À LA LETTRE.***

- 1.10.2. To reduce the risk of battery explosion, follow these instructions and those published by the battery manufacturer and the manufacturer of any equipment you intend to use in the vicinity of a battery. Review cautionary markings on these products and on the engine.

*Pour réduire le risque d'explosion, lire ces instructions et celles qui figurent sur la batterie.*

### 1.11. PERSONAL PRECAUTIONS

- 1.11.1. Someone should be within range of your voice or close enough to come to your aid when you work near a storage battery.
- 1.11.2. Have plenty of fresh water and soap nearby in case battery electrolyte contacts skin, clothing, or eyes.
- 1.11.3. Wear complete eye protection and clothing protection. Avoid touching eyes while working near a storage battery.
- 1.11.4. If battery electrolyte contacts skin or clothing, wash immediately with soap and water. If electrolyte enters eye, immediately flood the eye with running cold water for at least 10 minutes and get medical attention immediately.
- 1.11.5. **NEVER** smoke or allow a spark or flame in vicinity of battery or engine.

*Ne jamais fumer près de la batterie ou du moteur et éviter toute étincelle ou flamme nue à proximité de ces derniers.*

- 1.11.6. Be extra cautious to reduce risk of dropping a metal tool onto the battery. It might spark or short circuit the battery or another electrical part that may cause explosion. Using insulated tools reduces this risk, but will not eliminate it.
- 1.11.7. Remove personal metal items such as rings, bracelets, necklaces, and watches when working with a storage battery. A storage battery can produce a short circuit current high enough to weld a ring or the like to metal, causing a severe burn.
- 1.11.8. **When charging batteries, charge 6 and 12 cell LEAD-ACID or 10 and 20 cell LIQUID ELECTROLYTE NICKEL-CADMIUM batteries only, with rated capacity of 30 to 300 Ampere hours.** Charger certified for fire pump and emergency generator applications at 200 Ampere hours. Do not use this battery charger to supply power to an extra-low voltage electrical system or to charge any type of non-rechargeable, dry cell, alkaline, lithium, nickel-metal-hydride, or sealed nickel-cadmium batteries that are commonly used with home appliances. These batteries may burst and cause injuries to persons and damage to property.
- 1.11.9. **NEVER** charge a frozen battery.  
*Ne jamais charger une batterie gelée.*
- 1.11.10. The charger contains a DC output fuse for *internal* fault protection, but this will not protect the DC wiring from fault currents available *from the battery*. Consult national and local ordinances to determine if additional battery fault protection is necessary in your installation.

## 1.12. Preparing Battery For Charge

- 1.12.1. Be sure area around battery is well ventilated while battery is being charged.
- 1.12.2. Ensure battery terminals are clean and properly tightened. Be careful to keep corrosion from coming in contact with eyes.
- 1.12.3. Add distilled water in each cell until battery acid reaches level specified by battery manufacturer. Do not overfill. For a battery without removable cell caps, such as valve regulated lead acid batteries, carefully follow manufacturer's recharging instructions.
- 1.12.4. Study all battery manufacturer specific precautions such as removing or not removing cell caps while charging and recommended rate of charge. The recommended charge current range must include the rated output current of the charger.  
*Prendre connaissance des mesures de précaution spécifiées par le fabricant de la batterie, p. ex., vérifier s'il faut enlever les bouchons des cellules lors du chargement de la batterie, et les taux de chargement recommandés.*

## 1.13. Charger Location

- 1.13.1. Locate the charger as far away from the battery as DC cables permit.  
*Placer le chargeur aussi loin de la batterie que les cables c.c. le permettent.*
- 1.13.2. Never place the charger directly above or below the battery being charged; gases from the battery will corrode and damage charger.  
*Ne jamais placer le chargeur directement sous la batterie à charger ou au-dessus de cette dernière. Les gaz ou les fluides qui s'échappent de la batterie peuvent entraîner la corrosion du chargeur ou l'endommager.*
- 1.13.3. Never allow battery acid to drip on charger when reading electrolyte specific gravity or filling battery.
- 1.13.4. Do not operate charger in a closed-in area or restrict ventilation in any way.  
*Ne pas faire fonctionner le chargeur dans un espace clos et/ou ne pas gêner la ventilation.*
- 1.13.5. Do not set anything on top of the charger.



		<div style="text-align: center;"> <h3>Efficiency at 30VDC Output</h3> <table border="1"> <caption>Efficiency at 30VDC Output Data</caption> <thead> <tr> <th>Load (Amps)</th> <th>115 VAC Efficiency (%)</th> <th>230 VAC Efficiency (%)</th> </tr> </thead> <tbody> <tr><td>1</td><td>75.0</td><td>75.0</td></tr> <tr><td>2</td><td>85.0</td><td>85.0</td></tr> <tr><td>3</td><td>88.0</td><td>88.0</td></tr> <tr><td>4</td><td>90.0</td><td>90.0</td></tr> <tr><td>5</td><td>91.0</td><td>91.0</td></tr> <tr><td>6</td><td>91.5</td><td>91.5</td></tr> <tr><td>7</td><td>91.8</td><td>92.0</td></tr> <tr><td>8</td><td>92.0</td><td>92.5</td></tr> <tr><td>9</td><td>92.0</td><td>92.8</td></tr> <tr><td>10</td><td>92.0</td><td>93.0</td></tr> <tr><td>11</td><td>92.0</td><td>93.2</td></tr> <tr><td>12</td><td>92.0</td><td>93.5</td></tr> <tr><td>13</td><td>92.0</td><td>93.8</td></tr> <tr><td>14</td><td>92.0</td><td>94.0</td></tr> <tr><td>15</td><td>92.0</td><td>94.2</td></tr> </tbody> </table> </div>	Load (Amps)	115 VAC Efficiency (%)	230 VAC Efficiency (%)	1	75.0	75.0	2	85.0	85.0	3	88.0	88.0	4	90.0	90.0	5	91.0	91.0	6	91.5	91.5	7	91.8	92.0	8	92.0	92.5	9	92.0	92.8	10	92.0	93.0	11	92.0	93.2	12	92.0	93.5	13	92.0	93.8	14	92.0	94.0	15	92.0	94.2																																																		
Load (Amps)	115 VAC Efficiency (%)	230 VAC Efficiency (%)																																																																																																		
1	75.0	75.0																																																																																																		
2	85.0	85.0																																																																																																		
3	88.0	88.0																																																																																																		
4	90.0	90.0																																																																																																		
5	91.0	91.0																																																																																																		
6	91.5	91.5																																																																																																		
7	91.8	92.0																																																																																																		
8	92.0	92.5																																																																																																		
9	92.0	92.8																																																																																																		
10	92.0	93.0																																																																																																		
11	92.0	93.2																																																																																																		
12	92.0	93.5																																																																																																		
13	92.0	93.8																																																																																																		
14	92.0	94.0																																																																																																		
15	92.0	94.2																																																																																																		
	Power factor	>.95 typical at maximum rated load current and boost charge voltage																																																																																																		
DC output	Voltage	12/24V nominal; field selectable; adjustable from 0-34V using computer to charger cable and SENS Setup Utility Kit (SENS p/n 209254 plus SENS software available at <a href="http://www.sens-usa.com">www.sens-usa.com</a> )																																																																																																		
	Current	180W: 10A at 12V nominal and 6A at 24V nominal, 180W maximum																																																																																																		
		300W: 12A at 12V nominal and 10A at 24V nominal, 300W maximum																																																																																																		
		450W: 15A at 12/24V nominal, 450W maximum (12A max below 170VAC input voltage in 24V configuration)																																																																																																		
		<div style="text-align: center;"> <h3>Output Current Limit vs. Output Voltage</h3> <table border="1"> <caption>Output Current Limit vs. Output Voltage Data</caption> <thead> <tr> <th>Output Voltage (V)</th> <th>450W 208-240VAC</th> <th>450W 100-120VAC</th> <th>300W @ 12V</th> <th>300W @ 24V</th> <th>180W @ 12V</th> <th>180W @ 24V</th> </tr> </thead> <tbody> <tr><td>12.00</td><td>15.0</td><td>15.0</td><td>12.0</td><td>10.0</td><td>10.0</td><td>6.0</td></tr> <tr><td>13.00</td><td>15.0</td><td>15.0</td><td>12.0</td><td>10.0</td><td>10.0</td><td>6.0</td></tr> <tr><td>14.00</td><td>15.0</td><td>15.0</td><td>12.0</td><td>10.0</td><td>10.0</td><td>6.0</td></tr> <tr><td>15.00</td><td>15.0</td><td>15.0</td><td>12.0</td><td>10.0</td><td>10.0</td><td>6.0</td></tr> <tr><td>16.00</td><td>15.0</td><td>15.0</td><td>12.0</td><td>10.0</td><td>10.0</td><td>6.0</td></tr> <tr><td>17.00</td><td>15.0</td><td>15.0</td><td>12.0</td><td>10.0</td><td>10.0</td><td>6.0</td></tr> <tr><td>23.00</td><td>15.0</td><td>15.0</td><td>12.0</td><td>10.0</td><td>10.0</td><td>6.0</td></tr> <tr><td>23.33</td><td>15.0</td><td>15.0</td><td>12.0</td><td>10.0</td><td>10.0</td><td>6.0</td></tr> <tr><td>25.33</td><td>15.0</td><td>15.0</td><td>12.0</td><td>10.0</td><td>10.0</td><td>6.0</td></tr> <tr><td>27.33</td><td>15.0</td><td>15.0</td><td>12.0</td><td>10.0</td><td>10.0</td><td>6.0</td></tr> <tr><td>29.33</td><td>15.0</td><td>15.0</td><td>12.0</td><td>10.0</td><td>10.0</td><td>6.0</td></tr> <tr><td>31.33</td><td>15.0</td><td>15.0</td><td>12.0</td><td>10.0</td><td>10.0</td><td>6.0</td></tr> <tr><td>33.00</td><td>15.0</td><td>15.0</td><td>12.0</td><td>10.0</td><td>10.0</td><td>6.0</td></tr> </tbody> </table> </div>	Output Voltage (V)	450W 208-240VAC	450W 100-120VAC	300W @ 12V	300W @ 24V	180W @ 12V	180W @ 24V	12.00	15.0	15.0	12.0	10.0	10.0	6.0	13.00	15.0	15.0	12.0	10.0	10.0	6.0	14.00	15.0	15.0	12.0	10.0	10.0	6.0	15.00	15.0	15.0	12.0	10.0	10.0	6.0	16.00	15.0	15.0	12.0	10.0	10.0	6.0	17.00	15.0	15.0	12.0	10.0	10.0	6.0	23.00	15.0	15.0	12.0	10.0	10.0	6.0	23.33	15.0	15.0	12.0	10.0	10.0	6.0	25.33	15.0	15.0	12.0	10.0	10.0	6.0	27.33	15.0	15.0	12.0	10.0	10.0	6.0	29.33	15.0	15.0	12.0	10.0	10.0	6.0	31.33	15.0	15.0	12.0	10.0	10.0	6.0	33.00	15.0	15.0	12.0	10.0	10.0	6.0
	Output Voltage (V)	450W 208-240VAC	450W 100-120VAC	300W @ 12V	300W @ 24V	180W @ 12V	180W @ 24V																																																																																													
	12.00	15.0	15.0	12.0	10.0	10.0	6.0																																																																																													
13.00	15.0	15.0	12.0	10.0	10.0	6.0																																																																																														
14.00	15.0	15.0	12.0	10.0	10.0	6.0																																																																																														
15.00	15.0	15.0	12.0	10.0	10.0	6.0																																																																																														
16.00	15.0	15.0	12.0	10.0	10.0	6.0																																																																																														
17.00	15.0	15.0	12.0	10.0	10.0	6.0																																																																																														
23.00	15.0	15.0	12.0	10.0	10.0	6.0																																																																																														
23.33	15.0	15.0	12.0	10.0	10.0	6.0																																																																																														
25.33	15.0	15.0	12.0	10.0	10.0	6.0																																																																																														
27.33	15.0	15.0	12.0	10.0	10.0	6.0																																																																																														
29.33	15.0	15.0	12.0	10.0	10.0	6.0																																																																																														
31.33	15.0	15.0	12.0	10.0	10.0	6.0																																																																																														
33.00	15.0	15.0	12.0	10.0	10.0	6.0																																																																																														
	Soft start	Charger gradually increases current with a maximum of 5 seconds to full-required output																																																																																																		
	Charging modes	Float voltage, boost voltage; two additional HELIX charging voltages in flooded lead-acid battery program																																																																																																		
	Battery type programs	Flooded lead-acid, AGM or Ni-Cd for engine starting; VRLA for reserve power; ultracapacitor																																																																																																		
	DC power supply operation	Delivers fast-responding, stable, well-filtered DC without battery																																																																																																		
	Factory adjustment	All charger adjustments factory set to customer specifications; field reconfigurable																																																																																																		
	Field voltage	3 manually selectable voltage settings; optional keypad; infinite																																																																																																		

	adjustment	adjustment using computer to charger cable and SENS Setup Utility Kit (SENS p/n 209254 plus SENS software available at <a href="http://www.sens-usa.com">www.sens-usa.com</a> )
	Current limit	100% current capability subject to temperature limits and AC voltage limits on 450W; field adjustable
	Charging characteristic	Constant voltage, current limited; patented Dynamic Boost control
	Line/load regulation	±0.5%
	Output ripple	<30mVrms with or without battery
	Battery temperature compensation	On-board sensor controls changes in output voltage when temperature is between 0°C and +40°C at a rate of – 0.18% per degree C; optional remote battery temperature probe (SENS p/n 209481)
	Output protection	Current limit, supplementary overcurrent protection fuse (non-replaceable), transient protected
	Overvoltage protection	Self-resetting and selective
	Dead battery charge	Starts into and recharges zero volt battery without user intervention
	Parallel/Load Share operation	Two or more load-sharing chargers operate with all modes synchronized for increased current or fault tolerance, requires standard RJ-45 network cable to connect paralleling bus (SENS p/n 208118-72 for 72-inch length or p/n 208118-180 for 180-inch length)
	Load Dump protection	Output voltage over-shoot is limited to 15% to prevent damage to connected devices if battery is disconnected while charger is operating
	Output Blocking protection	Prevents sparking during battery connection when battery is first connected to charger; serves as an "OR" diode to isolate a non-functioning charger from others in a redundant charger configuration
Adjustment & Controls	Charge mode control	Fully automatic patented Dynamic Boost system. Fully automatic HELIX system for flooded lead-acid starting batteries that reduces power use and extends battery life.
	Internal adjustments	12 or 24 volt; battery type program; fine voltage setting
	Battery type programs	Flooded lead-acid, AGM or Ni-Cd for engine starting; VRLA for reserve power; ultracapacitor
	Computer adjustment	Change or customize settings from computer using computer to charger cable and SENS Setup Utility Kit (SENS p/n 209254 plus SENS software available at <a href="http://www.sens-usa.com">www.sens-usa.com</a> )
	Keypad adjustment	Enable or change all settings from front panel (requires optional keypad)
Status display	LEDs	Dual multi-color front panel status LEDs
	Digital metering	DC voltmeter accurate to ±2%; DC ammeter to ±5% (meters require optional display or network connection to a compatible device with a display). AC input voltage is for reference only. If AC waveform is not sinusoidal or is distorted the AC voltage will not be reported accurately.
	Status messages	20-character display of status and alarm messages (requires optional display or network connection to a compatible device with a display)
Alarms	Alarms	Factory set and field reconfigurable.
	Output via network	Alarms available via either J1939 or Modbus ports. Alarm indication delayed by configured alarm delay value.
	Form C contacts	Two or five Form C contacts, each rated 30VDC/VAC, 2A resistive, assignable at factory or by using SENS Setup Utility. Alarm indication

		delayed by configured alarm delay value.
	Alarm Delay	30 seconds by default, programmable between 5 to 60 seconds using keypad or SENS Setup Utility. Alarm indication delayed for communications ports and relay contacts, LED indication not delayed.
Networking	J1939 communications	CAN 2.0 extended ID on RJ-45 port
	Modbus communications	Modbus RS-485 on RJ-45 port
	SENSbus	Proprietary bus for connection of paralleled chargers and future SENS accessories
Environmental	Operating temperature	180W, enclosed: -40°C to +70°C; meets full specification from -40°C to +55°C
		180W, open-frame: -40°C to +70°C; meets full specification from -40°C to +60°C
		300W: -40°C to +70°C; meets full specification from -40°C to +50°C
		450W: -40°C to +70°C; meets full specification from -40°C to +40°C
		LCD: display may be unreadable and life reduced above 65°C
	Cooling	Natural convection cooled
	Storage temperature	-40°C to +85°C
	Cold Start	Cold starts down to -40°C. Requires approximately five seconds additional time to start at temperatures below -20°C.
	Humidity	5% to 95%, non-condensing
	Water ingress	Enclosed Models: IP 22; NEMA 3R; UL Rainproof
	Vibration	Swept Sine (EN60068-2-6): 4G, 18-500 Hz, 3 primary axes
		Random: 20-500Hz, .01G <sup>2</sup> /Hz
	Shock	EN 60068-2-27 (15G)
Electrical transient	ANSI/IEEE C62.41 and EN 61000-4-12 on power terminals	
Abuse protection	Reverse polarity	Charger self-protects without fuse clearing; indication via LED and optional LCD; charger recovers automatically after removal of the fault condition
	Wrong voltage battery	Charger-battery voltage mismatch shuts down charger after 5 minutes; indication via LED and optional LCD
	Overvoltage shutdown	Selective; shutdown only operates if charger causes the overvoltage condition. Overvoltage caused by an external voltage source does not shut down the charger.
	Over temperature protection	Gradual output power reduction if heatsink temperature becomes excessive
Regulatory compliance	North America	C-UL-US Listed (enclosed chassis): CSA 22.2, No. 107.2; UL 1236, File E109740 for category BBGQ and File EX6409 for categories BBHH, BBJY and QWIR; certified to UL 1236 supplements SB (marine), SC (fire pump) and SE (emergency generator) E109740 Note: 180W unit configured for 24V output is not compliant with QWIR2
		C-UL-US Recognized (open-frame chassis): CSA 22.2, No. 107.2; UL 1236, File E109740 for category BBGQ2 and File EX6409 for categories BBHH2, BBJY2 and QWIR2; certified to UL 1236 supplements SC (fire pump) and SE (emergency generator) Note: 180W unit configured for 24V output is not compliant with QWIR2
		NFPA-70; NFPA-110 when annunciating to the genset control panel



		<p>the charger’s output voltage &amp; current, and alarm status via J1939, or when equipped with optional alarm relays</p> <p>FCC: Part 15, Class B for home or commercial use and ICES-003 (Canada). This device complies with part 15 of the FCC Rules. Operation is subject to the following two conditions: (1) This device may not cause harmful interference, and (2) this device must accept any interference received, including interference that may cause undesired operation.</p> <p>Seismic: rigid and non-structure wall mount; max S<sub>DS</sub> of 2.5G; IBC 2000-2015; California BC 2007-2016</p> <p>American Bureau of Shipping: Type Approved</p> <p>California Energy Commission: Title 20 Appliance Efficiency Regulations</p>
	European Union (CE)	<p>EMC: 2014/30/EU EN 61000-6-4 (Emissions – Class B) CISPR 11 – Class B EN 61000-6-2 (Immunity – Industrial Environments) EN 61000-4-2 Electro Static Discharge 4 kV contact, 8 kV air EN 61000-4-3 Radiated Immunity – at 10V/m EN 61000-4-4 Electrical Fast Transients – 2kV AC, 1kV I/O EN 61000-4-5 Surge Immunity – 2 kV cm, 1 kV diff EN 61000-4-6 Conducted power line immunity – 10 V r.m.s. EN 61000-4-8 Power frequency magnetic field testing – 30 A/m EN 61000-4-11 Voltage dips and interruptions – per the standard</p> <p>LVD: 2014/35/EU EN 60335-1 &amp; EN 60335-2-29</p> <p>RoHS 2: 2011/65/EU EN 50581</p> <p>WEEE: 2012/19/EU This charger is considered electrical and electronic equipment (EEE) for non-household use and should be recycled accordingly. Do not dispose as unsorted municipal waste. See SENS website (<a href="http://www.sens-usa.com">www.sens-usa.com</a>) for information on how to properly recycle.</p>
Construction	Housing/configuration	Enclosed chassis: die-cast aluminum heatsink base with stainless steel covers and fasteners; includes two ½ inch conduit openings and one ¾ inch conduit opening
		Open-frame chassis: aluminum heatsink base and cover
	Dimensions	See drawings and dimensions at back of manual
	Weight	Enclosed: 6.0 lbs (2.7 Kg) Open-frame: 3.2 lbs (1.45 Kg)
Connections	AC and DC terminal blocks: 20 to 10 AWG solid copper; 20 to 6 AWG stranded copper	
	J-1939 and Modbus-485: RJ-45	
	Form C alarms terminal block plug: 28 to 16 AWG	

**4 SYSTEM OVERVIEW**

Fully enclosed model with optional alarm/communications circuit board shown. Refer to the nameplate label or the label on the inside lower cover for factory configured output and alarm relay assignments.

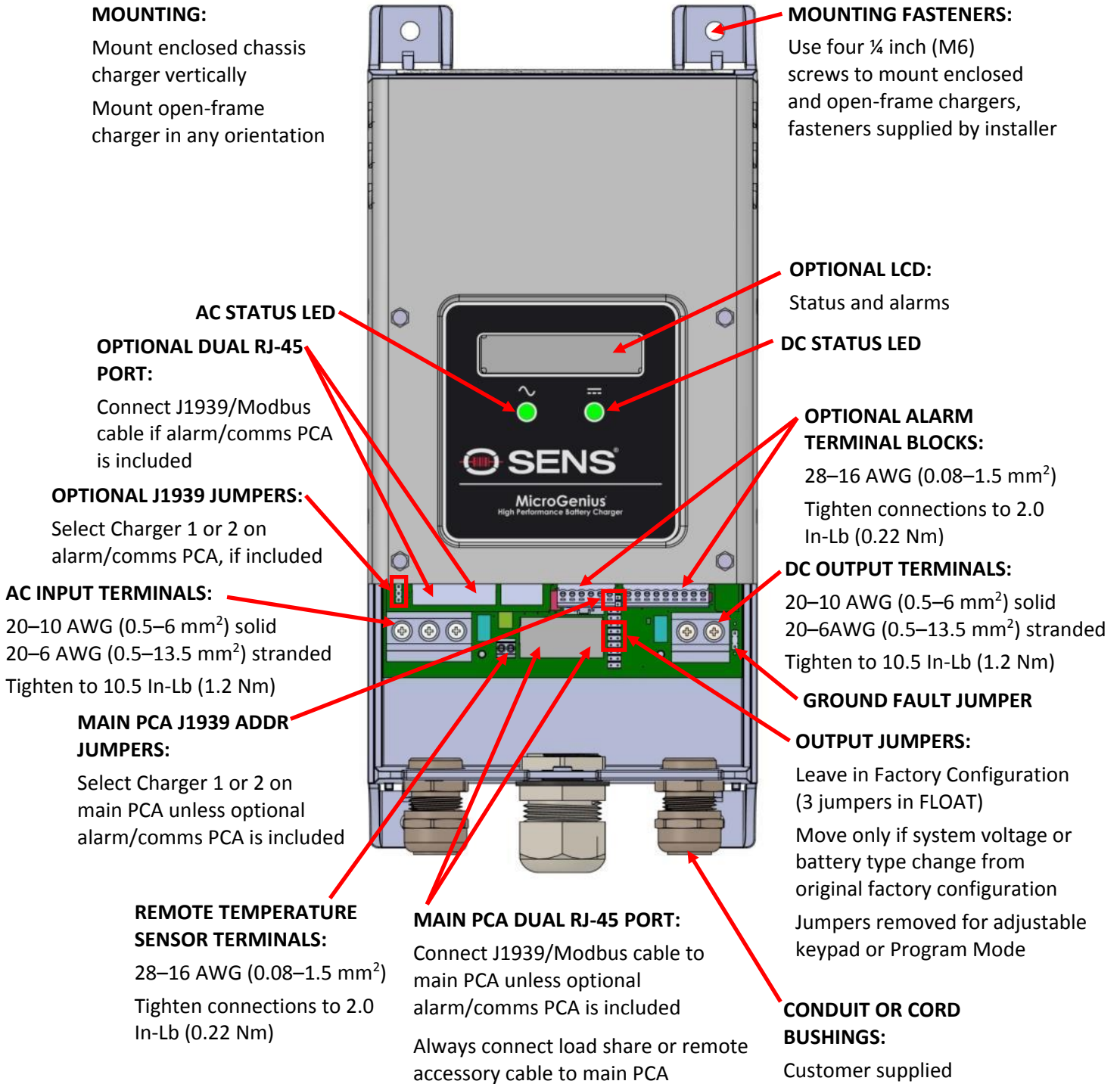

## 5 MOUNTING INSTRUCTIONS

**INSTALLATION OF THE UNIT MUST COMPLY WITH LOCAL ELECTRICAL CODES AND OTHER APPLICABLE INSTALLATION CODES AND BE MADE ACCORDING TO THE INSTALLATION INSTRUCTIONS AND ALL APPLICABLE SAFETY REGULATIONS.**

Printed circuit boards contain static sensitive components. Damage can occur even when static levels are too low to produce a noticeable discharge shock. To avoid static discharge damage, handle the charger by the chassis only. Remove the cover only when access is essential for installation and service, and replace it promptly when finished.

### 5.1. Mounting Location

The charger is provided in two different chassis options, fully enclosed or open-frame. See diagrams at back of manual for mounting information.

#### 5.1.1. Enclosed Chassis

5.1.1.1. The fully enclosed charger is rated IP22 and is approved as “rainproof” by UL. It can withstand dripping liquid but may require additional protection from spraying, splashing, or blowing liquid.

5.1.1.2. The charger will operate at full specification when located where temperatures are within the following ranges. Output power is gradually reduced at higher temperatures.

Power Rating	Operating Temperature
180W	-40°C (-40°F) to +55°C (131°F)
300W	-40°C (-40°F) to +50°C (122°F)
450W	-40°C (-40°F) to +40°C (104°F)

5.1.1.3. Mount charger vertically to ensure adequate ventilation.

5.1.1.4. Leave clear space for ventilation all around the enclosed unit: at least 6 inches (15 cm) at the top; at least 4 inches (10.16 cm) at the bottom; at least 0.5 inches (1.27 cm) on each side. Operating temperature ranges stated above assume clearances shown in diagram below.



5.1.1.5. Mount to a wall or other vertical support. The mounting surface must safely support the weight of the charger and the fixed wiring. The weight of the enclosed charger is 6 pounds (2.7 Kg).

#### 5.1.2. Open-frame Chassis

5.1.2.1. The open-frame chassis charger is designed for installation inside a customer-provided enclosure, protected from rain, snow and blowing or dripping liquid.

5.1.2.2. Heat sink the charger to a metal surface that is not subject to heating from another source. Base plate temperature should not exceed 83°C measured at top front of base plate when

charger is operating at full current load and maximum ambient temperature.

- 5.1.2.3. The charger will operate at full specification when located where temperatures are within the following ranges. Output power is gradually reduced at higher temperatures.

Power Rating	Operating Temperature
180W	-40°C (-40°F) to +60°C (140°F)
300W	-40°C (-40°F) to +50°C (122°F)
450W	-40°C (-40°F) to +40°C (104°F)

- 5.1.2.4. Mount charger in any orientation.

- 5.1.2.5. The mounting surface must safely support the weight of the charger and the fixed wiring. The weight of the open-frame charger is 3.2 pounds (1.45 Kg).

- 5.1.3. Allow sufficient room for routing the fixed wiring to the charger. All wires enter the charger from the bottom. See diagrams at back of manual for further information.

- 5.1.4. Do not mount the charger above any heat generating equipment.

## 5.2. Mounting Instructions

- 5.2.1. Drill four mounting holes using the mounting template provided with the charger.

**IMPORTANT: Protect charger from all drill shavings!**

- 5.2.2. Mount the charger before connecting AC, DC, communications and alarm wiring to ensure unobstructed access to mounting holes.

- 5.2.3. Mount the charger using four ¼ inch (M6) screws with standard flat washers. Mounting hardware is not included with the charger and must be provided by the installer.

**6 CHARGER SETUP**

**IMPORTANT!** The charger is configured at the factory and typically requires no adjustments before operating. Leave the jumpers in the three FLOAT positions to operate the charger using settings configured at the factory per customer order. Refer to the label on the inside lower cover for factory configured output and alarm relay assignments (see Figure 3). If the system voltage or battery type is different than the factory configuration, or if other custom settings are required, the charger may be reconfigured using the jumpers, the optional front panel keypad, or by software programming using the SENS Setup Utility.

**Figure 1 – Jumper Settings**  
(fully enclosed model with optional alarm/communications circuit board shown)

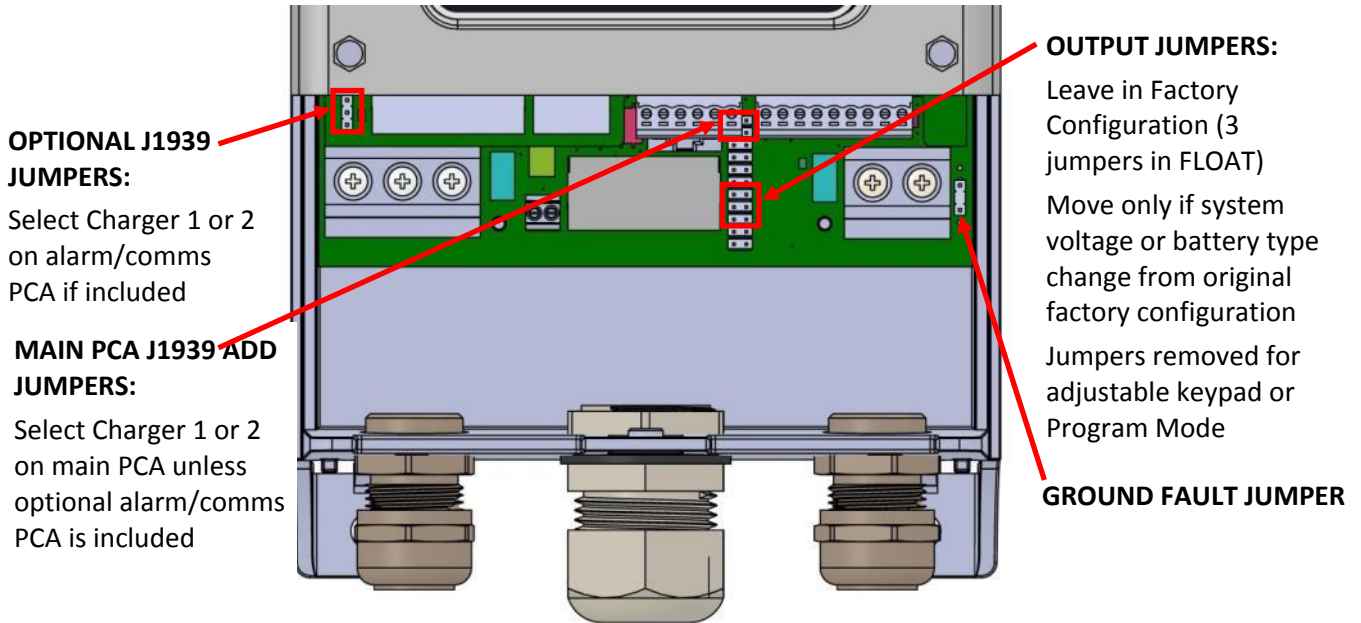

**6.1. Factory Jumper Configuration**

The charger is shipped from the factory with three jumpers in the three FLOAT positions on the main circuit board. Jumpers in the three FLOAT positions indicate the charger is operating using settings configured at the factory per customer order. Refer to the label on the inside lower cover for factory configured output and alarm relay assignments (see Figure 3). Leave jumpers in the factory configuration unless system voltage or battery type changes.

**Figure 2 – Factory Configuration**

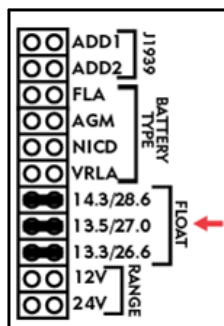
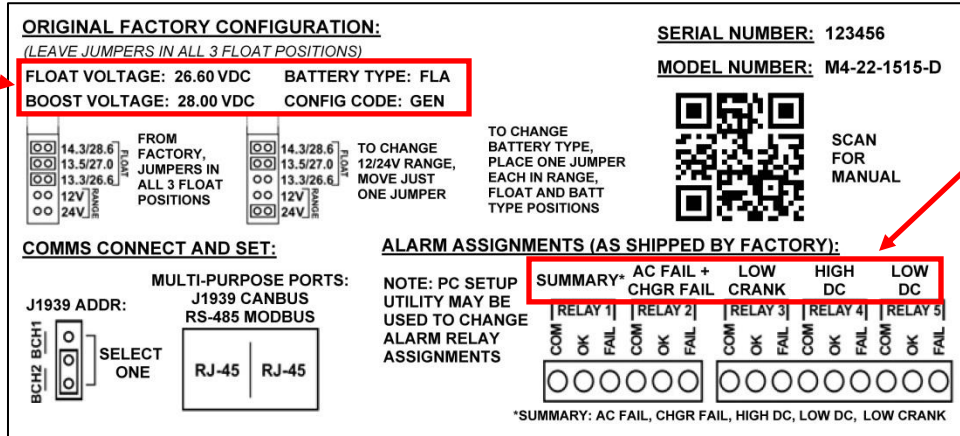

Figure 3 – Configuration Label (on inside lower cover)

View output voltage, battery type and configuration code set at the factory



View alarm relay assignments set at the factory

**6.1.1. Changing Voltage Range Using Factory Jumpers Mode**

The voltage range (12-volt or 24-volt battery) of the charger may be changed without changing factory settings by moving any one of the three FLOAT jumpers to the appropriate RANGE position. Set the RANGE jumper to 12V or 24V depending on nominal battery voltage. Leave the other two jumpers in the FLOAT positions. In this configuration the charging algorithm, output settings and alarm relay assignments remain as originally configured at the factory but all setpoints are doubled when changing from a 12V setting to a 24V setting or halved when changing from a 24V setting to a 12V setting. Replacing the jumpers in the three FLOAT positions will return the charger to original factory configuration.

Figure 4 – Change System Voltage

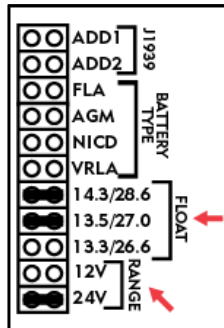

**6.1.2. Changing Battery Type Using Jumpers**

If battery type changes from original factory configuration, the Standard Jumper Configuration must be used (see section 6.2).

**6.2. Standard Jumper Configuration**

If battery type changes from the original factory configuration all jumpers must be moved into the standard jumper configuration - one jumper each in BATTERY TYPE, FLOAT and RANGE positions. In this configuration the alarm relay assignments remain as originally configured at the factory. Replacing the jumpers in the three FLOAT positions will return the charger to original factory configuration.

Figure 5 – Standard Jumper Configuration

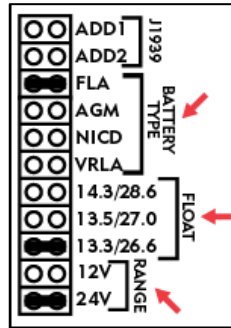

### 6.2.1. Battery Type Jumper

Set the BATTERY TYPE jumper appropriate for the battery type used.

Table 2 – Charging Algorithms by Battery Type

Battery Type	Charging Algorithm		
	Float Mode	Dynamic Boost Mode	HELIX Mode
FLA	✓	✓	✓
AGM	✓	✓	
NICD	✓	✓	
VRLA	✓		

#### 6.2.1.1. FLA

This setting is ideal for flooded lead-acid batteries used in engine starting applications. Set the BATTERY TYPE jumper to FLA when using flooded lead-acid batteries. The charging algorithm for flooded lead-acid batteries includes Float mode (see section [10.2](#)), Dynamic Boost™ mode (see section [10.3](#)) and HELIX mode (see section [10.4](#)).

#### 6.2.1.2. AGM

The term, “AGM” in this manual and for the MicroGenius charger refers to AGM type batteries that are employed in engine starting applications. For AGM type batteries employed in non-engine starting applications please see “VRLA” in section 6.2.1.4 below. Set the BATTERY TYPE jumper to AGM when using engine starting AGM batteries. The charging algorithm for absorbed glass mat batteries includes Float mode (see section [10.2](#)) and Dynamic Boost™ mode (see section [10.3](#)).

#### 6.2.1.3. NICD

Set the BATTERY TYPE jumper to NICD when using nickel-cadmium batteries. The charging algorithm for nickel-cadmium batteries includes Float mode (see section [10.2](#)) and Dynamic Boost™ mode (see section [10.3](#)). Nickel-cadmium batteries are used in all applications.

#### 6.2.1.4. VRLA

The “VRLA” battery profile includes all valve regulated batteries, including AGM types, which are employed in non-engine starting applications. For AGM batteries employed in engine starting applications please see “AGM” in section 6.2.1.2 above. Set the BATTERY TYPE jumper to VRLA when using valve-regulated lead-acid batteries, of which AGM is a subset. The charging algorithm for valve-regulated lead-acid batteries includes Float mode only (see section [10.2](#)).



### 6.2.1.5. Ultracapacitors

Place one jumper each in the AGM and NICD battery type positions and leave one jumper in the RANGE position if charging ultracapacitors rather than batteries (see section [10.5](#)).

### 6.2.2. Float Voltage Jumpers

When the charger is in Float mode the output voltage is maintained at the float voltage setting. If adjustment from the factory set float voltage is necessary, move the FLOAT output voltage jumper to the setting that is closest to the battery manufacturer's recommended 25°C (77°F) float voltage. Incorrect charge voltage can undercharge or accelerate generation of explosive gases, increasing the risk of fire or explosion.

Jumper options:

- 14.3/28.6 volts for 10 or 20 cell nickel cadmium at 1.43V/cell
- 13.5/27.0 volts for 6 or 12 cell (VRLA, AGM or high capacity) lead-acid at 2.25V/cell and 19 cell nickel cadmium at 1.42V/cell
- 13.3/26.6 volts for 6 or 12 cell (flooded) lead-acid at 2.22V/cell and 19 cell nickel cadmium at 1.40V/cell

The FLOAT output voltage setting is not used for charging ultracapacitors (see section [6.4](#) for ultracapacitor setup).

### 6.2.3. Range Jumper

Set the RANGE jumper to 12V or 24V depending on nominal battery voltage.

## 6.3. Keypad Configuration—*Optional*

Charger adjustment may also be made using the optional keypad. The keypad is either integral to the charger or located remotely from the charger and connected with a network cable. See section [7.9](#) for more information on the Remote Alarm/Communications Panel Accessory. Chargers including a keypad are supplied without jumpers and are configured per customer order at the factory. Jumpers must not be present to allow adjustment using the keypad. See section [10.9](#) for additional details on keypad navigation.

### 6.3.1. Security Code Protection

Chargers with the optional keypad may be security code protected to ensure only authorized personnel may adjust charger settings. The default security code is 000000 meaning security code is not enabled. Change the security code to a unique value by scrolling to the "Service Tools" menu and then the "Change Security Code" option. See section [10.9](#) for further keypad information.

## 6.4. Ultracapacitor Mode Setup

Ultracapacitor mode is used to charge ultracapacitors rather than batteries. Place a jumper in the 12V or 24V RANGE position and jumpers in both the AGM and NICD battery type positions (no jumpers are placed in the FLOAT settings) to enable operation with ultracapacitors.

### **WARNING:**

**ULTRACAPACITORS ACCEPT AND DISCHARGE CURRENT RAPIDLY. NEVER ATTEMPT TO JUMP OR CONNECT A BATTERY TO AN ULTRACAPACITOR.**



Figure 6 – Ultracapacitor Mode Jumper Configuration

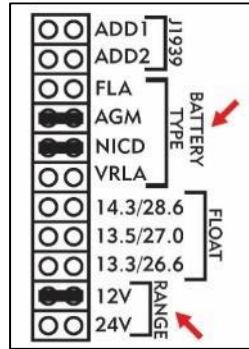

### 6.5. Program Mode

Removing all jumpers from the BATTERY TYPE, FLOAT and RANGE positions enables Program Mode. In Program Mode the charger output is determined by values programmed in the charger using the SENS Setup Utility (see section [10.10](#)). If the charger has not been specially programmed, removing all jumpers will result in an error state and the charger will not produce output. If the charger includes the optional keypad removing the jumpers is required to adjust settings and will not result in an error state (see section [6.3](#)).

### 6.6. Load Share Charger Setup

Multiple chargers may be connected in parallel to provide charger redundancy and increased charging current. Connection of a network cable between up to 30 chargers (see section [7.8](#)) automatically initiates load sharing. Use of this sharing cable is essential to synchronizing operation of the Dynamic Boost and HELIX modes, and helps insure that current is shared within  $\pm 10\%$  between chargers. Remove the ADD jumper, if present, from the main circuit board of any charger connected to load share (see Figure 8). Chargers intended for load sharing must be configured with the same output settings in order to load share. See section [10.12](#) for further information.

#### 6.6.1. Load Share Termination

For proper load share operation, a 120-ohm terminator is required at the ends of the bus. Figure 9 below shows an example of how to terminate the network. The charger is not equipped with terminators. Termination may be provided as part of the network cabling or 120-ohm termination plugs for the RJ-45 communications connector on the charger are available to order separately (SENS p/n 803707).

### 6.7. SAE J1939 Communications Setup (CANbus)

Every charger includes SAE J1939 (CANbus) communications. The J1939 interface provides a highly reliable, low cost method of delivering to the genset controller all information that NFPA 110 requires the battery charger to deliver. This eliminates the need for a volt/amp display and alarm relays in the charger. To be operational, the genset controller must support the charger's J1939 connection. Contact your genset supplier to determine if your genset supports a J1939-connected charger. See section [7.7](#) for J1939 wiring and section [11](#) for further information on J1939 operation and registers.

#### 6.7.1. Battery Charger J1939 Address Jumper

Configure the address jumper on the optional alarm/communications circuit board if present (see Figure 7). Otherwise, configure the address jumper on the main circuit board (see Figure 8). J1939 supports two chargers per network cable. Set the address jumper to position 1 for main charger or position 2 for auxiliary charger. The jumper is set to position 1 by default.

**Figure 7 – Optional Circuit Board J1939 Battery Charger (BCH) Jumper**



**Figure 8 – Main Circuit Board J1939 ADD Jumper**

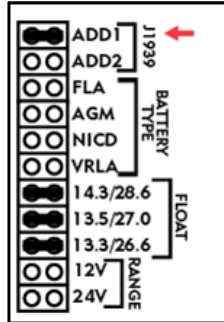

**6.7.2. Termination**

For proper J1939 operation, a 120-ohm terminator is required at the ends of the J1939 bus. If multiple devices are on the bus, only the devices on the ends of the network bus need termination resistors. Figure 9 shows an example of how to terminate the network. The charger is not equipped with terminators. Termination may be provided as part of the network cabling or 120-ohm termination plugs for the RJ-45 communications connector on the charger are available to order separately (SENS p/n 803707).

**Figure 9 – J1939 Termination**

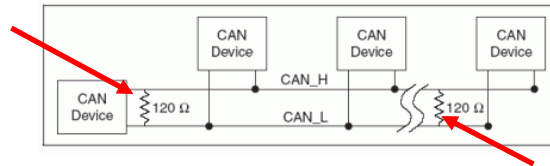

**6.8. Modbus Communications Setup**

Every charger includes Modbus (RS-485) communications. Modbus is an application layer messaging protocol used for client/server communication and is implemented according to specifications provided by Modbus Organization (<http://www.modbus.org/specs.php>). Modbus communications settings must be configured using the optional keypad or SENS Setup Utility prior to initiating. See section 7.7 for Modbus wiring and section 12 for further information on Modbus operation and configuration.

**6.8.1. Termination**

For proper Modbus RS-485 operation, a 120-ohm terminator is required at the ends of the RS-485 bus. If multiple devices are on the bus, only the devices on the ends of the network bus need termination resistors. Figure 10 shows an example of how to terminate the network. The charger is not equipped with terminators. Termination may be provided as part of the network cabling or 120-ohm termination plugs for the RJ-45 communications connector on the charger are available to order separately (SENS 803707).

Figure 10 – Modbus Termination

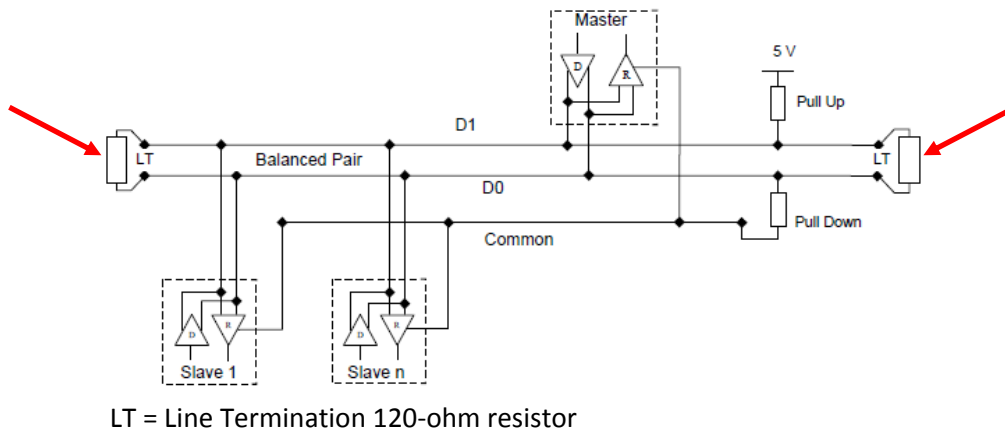

7 WIRING

All wiring must comply with applicable codes and local ordinances.

**WARNING:**  
**ENSURE THAT AC POWER IS DISCONNECTED AT A CIRCUIT BREAKER**  
**OR OTHER SAFETY DISCONNECT BEFORE WIRING THE CHARGER**

Figure 11 – Wire Connections

(Fully enclosed model with optional alarm/communications circuit board shown)

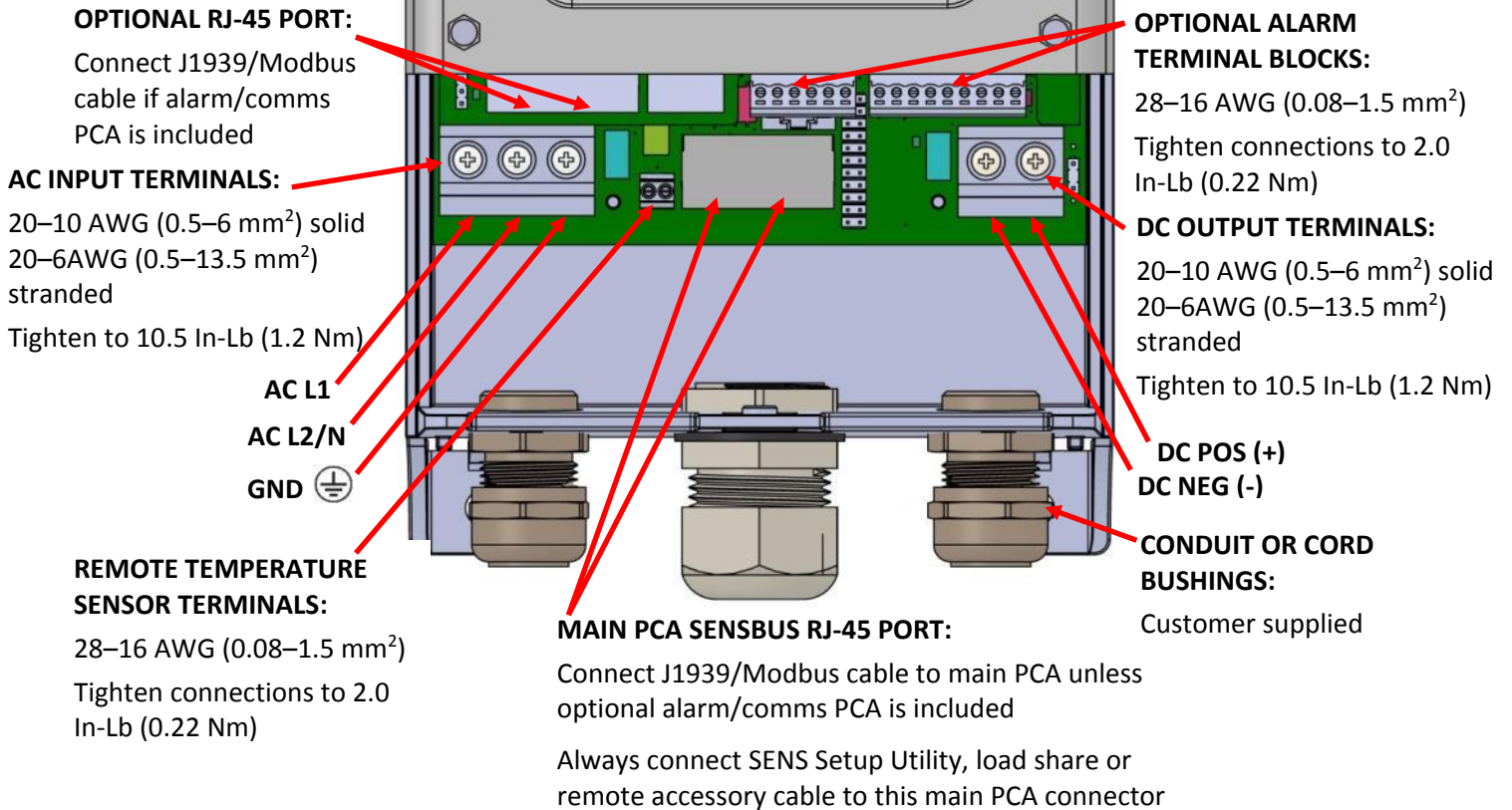

## 7.1. Wire Ratings and Sizes

- 7.1.1. All power conductors should be rated for use at 90°C or higher and 400V or higher. Alarm relay conductors and J1939 data cable should be rated for use at 75°C or higher.
- 7.1.2. Coordinate the AC input conductor size with the customer-provided branch circuit protection device.
- 7.1.3. For best performance and recharge time, refer to the following table to determine the appropriate output conductor gauge and length. Use of a remote temperature sensor (SENS p/n 209481, see section [7.6](#)) is highly recommended for best charging performance.

**Table 3 – DC Output Cable Size**

Charger Rated Output Current (Amps)	Wire Size		Resistance per Foot (mΩ/Ft.)	Maximum Charger to Battery Distance (Ft.)		Recommended Charger to Battery Distance (Ft.)	
	AWG	mm <sup>2</sup>		12V	24V	12V	24V
6	14	2.5	2.50	N/A	33	N/A	13
	12	4.0	1.60	N/A	52	N/A	21
	10	6.0	1.00	N/A	83	N/A	33
	8	10	0.63	N/A	132	N/A	53
	6	16	0.40	N/A	208	N/A	83
10	14	2.5	2.50	10	20	4	8
	12	4.0	1.60	16	32	6	12
	10	6.0	1.00	25	50	10	20
	8	10	0.63	40	80	15	30
	6	16	0.40	63	126	24	48
12	14	2.5	2.50	8	N/A	3	N/A
	12	4.0	1.60	13	N/A	5	N/A
	10	6.0	1.00	21	N/A	8	N/A
	8	10	0.63	33	N/A	13	N/A
	6	16	0.40	52	N/A	21	N/A
15	14	2.5	2.50	6	12	2	4
	12	4.0	1.60	10	20	4	8
	10	6.0	1.00	17	34	7	14
	8	10	0.63	26	52	11	22
	6	16	0.40	42	84	17	34

The above lengths consider the resistance of the battery and cables only and do not take into account any additional interconnects. The above lengths are for operation at 25°C/77°F. For high temperature installations (40°C/104°F) increase wire gauge by 10%.

7.1.4. The charger terminal blocks accept the following wire gauge ranges:

- AC input terminal block: 20 – 10 AWG (0.5 – 6 mm<sup>2</sup>) solid; 20 – 6 AWG (0.5 – 13.5 mm<sup>2</sup>) stranded
- Remote temperature sensor terminal block: 28 – 16 AWG (0.08 – 1.5 mm<sup>2</sup>)
- DC output terminal block: 20 – 10 AWG (0.5 – 6 mm<sup>2</sup>) solid; 20 – 6 AWG (0.5 – 13.5 mm<sup>2</sup>) stranded
- Alarm terminal block: 28 – 16 AWG (0.08 – 1.5 mm<sup>2</sup>)

## 7.2. Grounding Instructions and Connection

- 7.2.1. Charger must be grounded to reduce risk of electric shock. The charger must be connected to a grounded, metal, permanent wiring system, or an equipment-grounding conductor (earthing conductor) must be run with the circuit conductors and connected to equipment-grounding terminal on charger.
- 7.2.2. Connect the equipment grounding conductor to the ground position on the AC input terminal block in the charger (see Figure 11). This position is marked with the ground symbol. This should always be the first wire connected and the last wire disconnected.
- 7.2.3. The charger may be equipped with an optional power cord having an equipment-grounding conductor and a grounding plug. The plug must be plugged into an outlet that is properly installed and grounded in accordance with all local codes and ordinances.

**DANGER:**  
**NEVER ALTER AC CORD OR PLUG PROVIDED – IF IT WILL NOT FIT OUTLET, HAVE PROPER OUTLET INSTALLED BY A QUALIFIED ELECTRICIAN. IMPROPER CONNECTION CAN RESULT IN A RISK OF AN ELECTRIC SHOCK.**

## 7.3. DC Connection

Ensure that any battery disconnect device in the system, if used, is opened (batteries disconnected from DC bus). Connect the DC output conductors to the DC output terminal block in the charger (see Figure 11). Always observe proper polarity of the DC output leads. Always connect the output leads in the following order – charger output to ungrounded battery terminal, followed by charger output to grounded battery terminal. If the battery must be disconnected for service, remove the output wiring in the reverse order. The terminals accept 20 through 10 AWG (0.5 through 6 mm<sup>2</sup>) solid copper conductors and 20 through 6 AWG (0.5 through 13.5 mm<sup>2</sup>) stranded copper conductors. Tighten connections to 10.5 Lb-In (1.2 Nm) using a Phillips slotted #2 driver. Route DC wiring at least ¼ inch (6 mm) away from AC wiring, alarm wiring, and the circuit board.

**WARNING:**  
**A MAXIMUM OF 40 VOLTS MAY BE APPLIED AT THE OUTPUT TERMINALS. HIGHER VOLTAGE MAY DAMAGE THE CHARGER.**

## 7.4. AC Connection

This unit is permanently connected to the AC circuit and to the battery. An external disconnect device must be located in the AC input to the charger. The charger is rated to operate on any AC input within the range of 90-265VAC, 47-63Hz.

Ensure that the AC input supply is de-energized. Connect the AC line, neutral and ground conductors to the AC input terminal block in the charger (see Figure 11). If there is an identified grounded circuit conductor (neutral), attach it to the terminal marked “L2/N.” The terminals accept 20 through 10 AWG (0.5 through 6 mm<sup>2</sup>) solid copper conductors and 20 through 6 AWG (0.5 through 13.5 mm<sup>2</sup>) stranded copper conductors. Tighten connections to 10.5 Lb-In (1.2 Nm) using a Phillips slotted #2 driver. Route AC wiring at least ¼ inch (6 mm) away from DC wiring, alarm wiring, and the circuit board.

## 7.5. Alarm Connections—*Optional*

If the optional alarm/communications circuit board is included, connect alarm wiring to the respective terminals on the pluggable terminal block in the charger (see Figure 11 for location in charger and Figure 12 for detail). To make wiring easier, the terminal block unplugs from the header. Pull terminal block straight out from header to remove. Connect wires to terminal block by tightening screws at each position. After wires are connected, plug terminal block securely back into header. Alarm relay assignments are custom configurable. See charger inside cover label for original factory alarm relay assignments. Wire from FAIL or OK to COM depending on whether the alarm should be present on an open or closed circuit (see Table 4-6). Connect alarm terminals only to low voltage, limited energy (“Class

2”) circuits. Alarm circuits are rated 2A at 30V AC or DC. The terminals accept 28-16 AWG (0.08-1.5 mm<sup>2</sup>) conductors. Tighten connections to 2.0 Lb-In (0.22 Nm) using a small slotted driver. Route alarm wiring at least ¼ inch (6 mm) away from DC wiring, AC wiring, and the circuit board.

**Figure 12– Pluggable Terminal Block**  
(TB2 pins 1-9 shown)

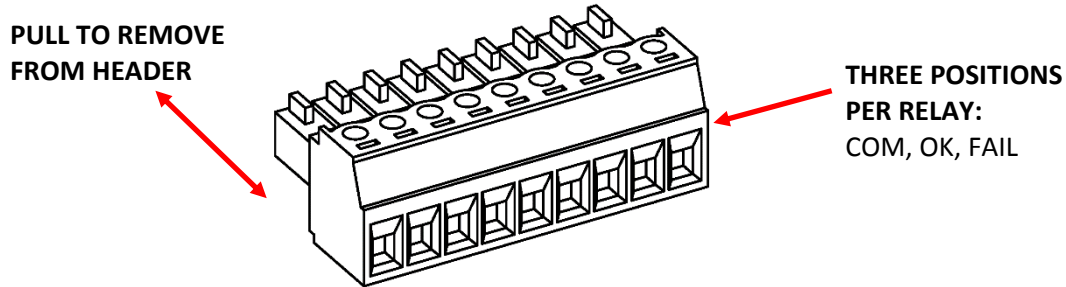

**Table 4 – Alarm Relay Contact Wiring for Genset Configuration**

Wire from COM to OK for alarm present on open circuit or from COM to FAIL for present on closed circuit.

	RELAY 1	RELAY 2	RELAY 3	RELAY 4	RELAY 5
<b>Relay Contacts</b>	<b>Summary Alarm*</b>	<b>AC Fail + Charger Fail Alarm</b>	<b>Low Crank Alarm</b>	<b>High DC Alarm</b>	<b>Low DC Alarm</b>
<b>Common</b>	COM (TB1-1)	COM (TB1-4)	COM (TB2-1)	COM (TB2-4)	COM (TB2-7)
<b>Open on alarm (normally closed)</b>	OK (TB1-2)	OK (TB1-5)	OK (TB2-2)	OK (TB2-5) Defaults to OK with no AC and DC power	OK (TB2-8)
<b>Close on alarm (normally open)</b>	FAIL (TB1-3) Defaults to FAIL with no AC input	FAIL (TB1-6) Defaults to FAIL with no AC input	FAIL (TB2-3) Defaults to FAIL with no AC and DC power	FAIL (TB2-6)	FAIL (TB2-9) Defaults to FAIL with no AC and DC power

\*Summary alarm includes AC Fail, Charger Fail, Low Crank, High DC and Low DC alarms.

**Table 5 – Alarm Relay Contact Wiring for Marine Configuration**

Wire from COM to OK for alarm present on open circuit or from COM to FAIL for present on closed circuit.

	RELAY 1	RELAY 2	RELAY 3	RELAY 4	RELAY 5
<b>Relay Contacts</b>	<b>Summary Alarm*</b>	<b>AC Fail</b>	<b>Ground Fault Alarm</b>	<b>High DC Alarm</b>	<b>Low DC Alarm</b>
<b>Common</b>	COM (TB1-1)	COM (TB1-4)	COM (TB2-1)	COM (TB2-4)	COM (TB2-7)
<b>Open on alarm (normally closed)</b>	OK (TB1-2)	OK (TB1-5)	OK (TB2-2) Defaults to OK with no AC and DC power	OK (TB2-5) Defaults to OK with no AC and DC power	OK (TB2-8)
<b>Close on alarm (normally open)</b>	FAIL (TB1-3) Defaults to FAIL with no AC input	FAIL (TB1-6) Defaults to FAIL with no AC input	FAIL (TB2-3)	FAIL (TB2-6)	FAIL (TB2-9) Defaults to FAIL with no AC and DC power

\*Summary alarm includes AC Fail, Charger Fail, Ground Fault, High DC and Low DC alarms.

**Table 6 – Alarm Relay Contact Wiring for Stationary Power Configuration**

Wire from COM to OK for alarm present on open circuit or from COM to FAIL for present on closed circuit.

	RELAY 1	RELAY 2	RELAY 3	RELAY 4	RELAY 5
<b>Relay Contacts</b>	<b>Summary Alarm*</b>	<b>AC Fail</b>	<b>Battery Discharging Alarm</b>	<b>High DC Alarm</b>	<b>Low DC Alarm</b>
<b>Common</b>	COM (TB1-1)	COM (TB1-4)	COM (TB2-1)	COM (TB2-4)	COM (TB2-7)
<b>Open on alarm (normally closed)</b>	OK (TB1-2)	OK (TB1-5)	OK (TB2-2)	OK (TB2-5) Defaults to OK with no AC and DC power	OK (TB2-8)
<b>Close on alarm (normally open)</b>	FAIL (TB1-3) Defaults to FAIL with no AC input	FAIL (TB1-6) Defaults to FAIL with no AC input	FAIL (TB2-3) Defaults to FAIL with no AC and DC power	FAIL (TB2-6)	FAIL (TB2-9) Defaults to FAIL with no AC and DC power

\*Summary alarm includes AC Fail, Charger Fail, Battery Discharging, High DC and Low DC alarms.

**7.6. Remote Temperature Sensor Connection—Optional**

The charger includes local temperature compensation using an internal on-board sensor. Alternately, the charger will use remote temperature compensation based on the temperature of the batteries when an optional external sensor is located at the batteries and connected to the main circuit board remote temperature sensor terminal block (see Figure 11). Remote temperature compensation is required for ultracapacitor charging and is highly recommended in all applications. It is most critical in applications where battery and charger are located in different ambient conditions and in NFPA-20 fire pump and NFPA-110 emergency power system installations in order to return 100% of the battery's ampere-hour rating within 24 hours without causing damage to the battery. Temperature compensation is disabled by connecting a short across the remote temperature sensor terminal block on the main circuit board, using the optional keypad or by setting the temperature compensation slope to zero using the SENS Setup Utility. See section [10.11](#) for further information regarding temperature compensation. A 50-foot remote temperature sensor is available to order separately (SENS p/n 209481).

The remote temperature sensor is not polarized; it does not matter which lead connects to each terminal. Route sensor wiring at least ¼ inch (6 mm) away from DC wiring, AC wiring, and the circuit board. Locate the remote sensor where it will accurately detect the battery temperature by connecting it to a *grounded* battery terminal or the battery case. When securing to the battery case, use an adhesive/glue properly rated for the application material and temperature, such as Super Glue®.

**7.7. J1939/Modbus Communications Connection**

Connect either J1939 or Modbus communications using a twisted pair cable at the RJ-45 connector on the optional alarm/communications circuit board if present (see Figure 11 for location in charger and Figure 13 for detail). Connect the communications cable to the main circuit board RJ-45 connector if the optional alarm/communications circuit board is not present. Chargers with only the main circuit board support J1939 or SENSbus devices (load sharing charger or remote accessory) but not both at the same time. If both J1939 and a remote SENSbus accessory or load sharing are desired the optional alarms/communications circuit board must be included.

Two RJ-45 ports are provided on both the main and optional alarms/communications circuit boards (see Figure 13). On each circuit board the ports are in parallel and either port may be used. Use the second port to connect chargers for load sharing (see section [7.8](#)) or remote accessories (see section [7.9](#)). See



Table 7 for connector pinout. An adapter from RJ-45 to an 8-position terminal block may be connected to the RJ-45 connector and is available to order separately (SENS p/n208026).

Communications are non-isolated and referenced to negative battery terminal.

**Figure 13 – RJ-45 Connection**

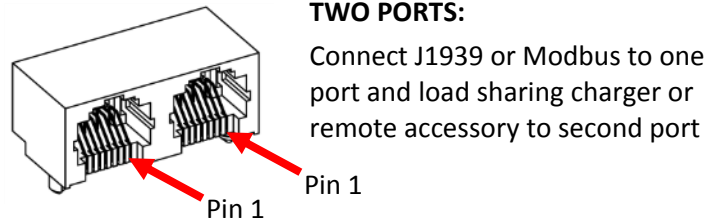

**Table 7 – Connector Pinout**

Pin #	Purpose
1	J1939 Data High/SENSbus
2	J1939 Data Low/SENSbus
3	No connect pass-through
4	Modbus –D0 (B)
5	Modbus +D1 (A)
6	No connect pass-through
7	Power*
8	Common (referenced to battery negative)

\*Main circuit PCA only, used for interconnect between SENS devices

### 7.8. Load Share Connection—*Optional*

Connect a network cable from one charger to another using the RJ-45 ports on each charger to automatically initiate load sharing. Two RJ-45 ports are provided on the main circuit board (see Figure 11 for location in charger and Figure 13 for detail). The ports are in parallel and either port may be used for the load share connection.

### 7.9. Remote Alarm/Communications Panel Accessory Connection—*Optional*

Connect remote accessories to the charger using a network cable connected to the RJ-45 port on the charger main circuit board. Two RJ-45 ports are provided on the main circuit board (see Figure 11 for location in charger and Figure 13 for detail). Connect a network cable from the remote accessory to one port and a 120-ohm terminator to the second port. Connect the other end of the network cable to the RJ-45 splitter connected to the RJ-45 port on the remote accessory circuit board.

For proper operation, a 120-ohm terminator is required at both ends of the communications bus. Remote accessories are provided with a terminator installed in the 2-position RJ-45 splitter connected to the RJ-45 port located on the remote accessory circuit board. Remove the terminator on the splitter only if the remote accessory is not at the end of the communications bus.

The remote accessory may be connected to multiple chargers. In this case, the remote accessory, chargers or other equipment, such as a genset controller, may be located at the ends of the communications bus. Ensure a terminator is located at both ends of the communications bus.



## 7.10. Verify Connections

- 7.10.1. Verify that all connections are secure and in the proper locations. Tighten all unused screws on the terminal blocks to secure them against vibration.
- 7.10.2. Ensure all wires are routed in a way that the cover or other objects will not pinch or damage them.

## 8 POWER ON/POWER OFF PROCEDURE

---

### 8.1. Connect Battery

Ensure wiring is correctly connected between charger and battery. Close any system battery disconnect, if used, to connect the battery to the charger.

### 8.2. Apply AC Input Voltage

Verify the AC input is the correct value (90-265 VAC, 47-63 Hz) and apply AC to charger.

Depending on the state of charge of the batteries and the load on the DC bus, the charger may go into current limit at this time, in which case the output voltage will be reduced as the charger operates in constant current mode. Eventually as the battery is charged, the charging current demand should taper to a value below the current limit setpoint of the charger, and the charger should revert to constant voltage output.

### 8.3. Power Off

Power charger off in any order or remove any jumper (if charger is not in Program Mode) to disable output voltage.

## 9 ALARMS, LEDS AND DISPLAY

---

### 9.1. LED Indicators

The charger is equipped with two LEDs, one for AC status and one for DC status. See further alarm definitions in section [9.4](#).

**Table 8 – LED Definitions**

AC LED	DC LED	Meaning
OFF	OFF	AC and DC not applied or charger failed or optional alarm/communications circuit board cannot communicate with main circuit board
*SOLID GREEN	SOLID GREEN	AC good, DC good, in Float Mode
SOLID GREEN	FLASHING GREEN	AC good, in Dynamic Boost Mode
*SOLID GREEN	FLASHING 2X GREEN	AC good, DC in current limit (max charge)
*SOLID GREEN	FLASH LONG-SHORT GREEN	AC good, HELIX Eco-Float mode
*SOLID GREEN	FLASH LONG-2X SHORT GREEN	AC good, HELIX Refresh Charge mode
*SOLID GREEN	FLASH LONG-SHORT YELLOW	AC good, battery commissioning mode active
*SOLID GREEN	FAST FLASHING GREEN	AC good, battery check in progress
*SOLID GREEN	FAST FLASHING YELLOW	AC good, battery check failure
*SOLID GREEN	SOLID RED	AC good, charger fail or overvoltage shutdown (charger disabled)
*SOLID GREEN	FLASHING RED/YELLOW	AC good, reverse polarity detected on output
*SOLID GREEN	SOLID YELLOW	AC good, high or low DC voltage (above/below alarm setpoint)
*SOLID GREEN	FLASHING GREEN/RED	For multi-charger system with optional alarm/communications circuit board only: AC

		good, system DC output good, some individual charger(s) in alarm state
*SOLID GREEN	FLASHING YELLOW	AC good, low incompatible battery error (charger disabled)
*SOLID GREEN	FLASHING GREEN/YELLOW	AC good, output limited by high temperature
*SOLID GREEN	DOUBLE FLASH YELLOW	AC good, load share fail
*SOLID GREEN	DOUBLE FLASH RED	AC good, load sharing DC negative connection open or load sharing charger address fault
SOLID RED	SOLID GREEN	AC fail, DC voltage good
SOLID RED	SOLID YELLOW	AC fail, high or low DC voltage (above/below alarm setpoint)
SOLID RED	SOLID RED	AC fail, charger fail or overvoltage shutdown (charger disabled)
SOLID RED	FLASHING YELLOW	AC fail, low incompatible battery error (charger disabled)
ALTERNATING FLASHING YELLOW		Illegal jumper configuration
ALTERNATING FLASHING RED		Missing or invalid code (boot load required)
ALTERNATING FLASHING GREEN		Charger starting up

\*AC LED will flash green when charger is in ultracapacitor mode.

## 9.2. Individual Alarm Relay Contacts—*Optional*

The optional alarm/communications circuit board offers two or five alarm discrete Form C contacts. The Form C relay contacts change state when alarms are activated (see Tables 4-6). Alarm relay assignments are custom configurable to any of the alarm functions listed in section 9.4. See charger inside cover label for original factory alarm relay assignments. See Tables 4-6 for typical alarm relay assignments.

The relay contacts change state 30 seconds after the onset of a fault or after a programmable time period when the charger is in Program Mode (see section 10.10). See section 9.4 for alarm definitions.

## 9.3. LCD Panel—*Optional*

If the optional alarm/communications circuit board is included, a two line by twenty-character LCD is present and provides precision digital ammeter and voltmeter as well as information about input, output, charging status and alarms. The voltmeter is accurate to  $\pm 2\%$  and the ammeter is accurate to  $\pm 5\%$ . The display is readable with or without ambient lighting and operates automatically, requiring no operator intervention.

The LCD is fully operational from  $-20^{\circ}\text{C}$  to  $+40^{\circ}\text{C}$ . It may temporarily become unreadable below  $-20^{\circ}\text{C}$  but should recover as temperature increases. LCD life is reduced with sustained operation above  $65^{\circ}\text{C}$ .

## 9.4. Alarm Definitions

See Table 8 for a description of LED indicator activity. Unless noted otherwise, the following alarms are displayed on the optional LCD panel if it is included.

### 9.4.1. AC Line Failure

Indicates AC input voltage is not applied or is outside of allowed 90-265 VAC range. Activates solid red AC LED. Optional alarm/communications circuit board AC FAIL relay contacts change to Fail state after delay when alarm is assigned to relay contacts.

### 9.4.2. High DC Voltage

Indicates DC output voltage is above factory alarm setpoint (see Table 9), standard jumper configuration setpoint (see Table 10), or the programmed level if the charger is in Program Mode. Activates solid yellow DC LED. Optional alarm/communications circuit board HIGH DC relay contacts change to Fail state after delay when alarm is assigned to relay contacts.

**Table 9 – Factory Jumper Configuration High DC Setpoints**

Configuration Code*	Battery Type	High DC Setpoint	
		12V	24V
GEN	AGM	16.00	32.00
	FLA	16.00	32.00
	NICD	16.00	32.00
	HCB	16.00	32.00
	Ultracapacitor	17.00	28.00
MAR	VRLA	14.64	29.28
	AGM	14.82	29.64
	NCD	16.00	32.00
NGN	VRLA	14.64	29.28
	AGM	14.82	29.64
	NCD	16.00	32.00
PSP	N/A	13.20	26.40

\*Configuration Code displayed on charger label.

**Table 10 – Standard Jumper Configuration High DC Setpoints**

Battery Range	Float Jumper	High DC Setpoint
12V	13.3/26.6	16.00
	13.5/27.0	
	14.3/28.6	
	Ultracap Mode	17.00
24V	13.3/26.6	32.00
	13.5/27.0	
	14.3/28.6	
	Ultracap Mode	28.00

### 9.4.3. Battery Discharging

Indicates battery is beginning to discharge and DC output voltage is below factory alarm setpoint (see Table 13), standard jumper configuration setpoint (see Table 14), or the programmed level if the charger is in Program Mode. Alarm setpoint must be set higher than LOW DC alarm. Activates solid yellow DC LED. Optional alarm/communications circuit board BATTERY DISCHARGING relay contacts change to Fail state after delay when alarm is assigned to relay contacts.

**Table 13 – Factory Jumper Configuration Battery Discharging Setpoints**

Configuration Code*	Battery Type	Battery Discharging Setpoint	
		12V	24V
GEN	AGM	12.50	25.00
	FLA	12.50	25.00
	NICD	12.50	25.00
	HCB	12.50	25.00
	Ultracapacitor	14.40	24.00
MAR	VRLA	12.00	24.00
	AGM	12.00	24.00
	NCD	12.00	24.00
NGN	VRLA	12.00	24.00
	AGM	12.00	24.00
	NCD	12.00	24.00
PSP	N/A	10.20	20.40

\*Configuration Code displayed on charger label.

**Table 14 – Standard Jumper Configuration Battery Discharging Setpoints**

Battery Range	Float Jumper	Battery Discharging Setpoint
12V	13.3/26.6	12.50
	13.5/27.0	12.50
	14.3/28.6	12.50
	Ultracap Mode	12.00
24V	13.3/26.6	25.00
	13.5/27.0	25.00
	14.3/28.6	25.00
	Ultracap Mode	24.00

**9.4.4. Low DC Voltage**

Indicates battery has discharged and DC output voltage is below factory alarm setpoint (see Table 11), standard jumper configuration setpoint (see Table 12), or the programmed level if the charger is in Program Mode. Activates solid yellow DC LED. Optional alarm/communications circuit board LOW DC relay contacts change to Fail state after delay when alarm is assigned to relay contacts.

**Table 11 – Factory Jumper Configuration Low DC Setpoints**

Configuration Code*	Battery Type	Low DC Setpoint	
		12V	24V
GEN	AGM	12.10	24.20
	FLA	12.10	24.20
	NICD	12.10	24.20
	HCB	12.10	24.20
	Ultracapacitor	13.00	22.40
MAR	VRLA	11.00	22.00
	AGM	11.00	22.00
	NCD	11.00	22.00
NGN	VRLA	11.00	22.00
	AGM	11.00	22.00
	NCD	11.00	22.00
PSP	N/A	10.20	20.40

\*Configuration Code displayed on charger label.

**Table 12 – Standard Jumper Configuration Low DC Setpoints**

Battery Range	Float Jumper	Low DC Setpoint
12V	13.3/26.6	12.10
	13.5/27.0	
	14.3/28.6	
	Ultracap Mode	13.00
24V	13.3/26.6	24.20
	13.5/27.0	
	14.3/28.6	
	Ultracap Mode	22.40

#### 9.4.5. Battery End of Discharge

Indicates DC output voltage is below factory alarm setpoint (see Table 15), standard jumper configuration setpoint (see Table 16), or the programmed level if the charger is in Program Mode. This alarm is intended only for longer discharge rates (i.e. not engine starting applications) and indicates the normal end-of-discharge voltage for a lead-acid battery. Alarm setpoint must be set lower than LOW DC and BATTERY DISCHARGING alarms. Activates solid yellow DC LED. Optional alarm/communications circuit board BATTERY END OF DISCHARGE relay contacts change to Fail state after delay when alarm is assigned to relay contacts.

**Table 15 – Factory Jumper Configuration Battery End of Discharge Setpoints**

Configuration Code*	Battery Type	Battery End of Discharge Setpoint	
		12V	24V
GEN	AGM	10.50	21.00
	FLA	10.50	21.00
	NICD	10.50	21.00
	HCB	10.50	21.00
	Ultracapacitor	10.50	21.00
MAR	VRLA	10.50	21.00
	AGM	10.50	21.00
	NCD	10.50	21.00
NGN	VRLA	10.50	21.00
	AGM	10.50	21.00
	NCD	10.50	21.00
PSP	N/A	10.20	20.40

\*Configuration Code displayed on charger label.

**Table 16 – Standard Jumper Configuration Battery End of Discharge Setpoints**

Battery Range	Float Jumper	Battery End of Discharge Setpoint
12V	13.3/26.6	10.50
	13.5/27.0	
	14.3/28.6	
	Ultracap Mode	
24V	13.3/26.6	21.00
	13.5/27.0	
	14.3/28.6	
	Ultracap Mode	

#### 9.4.6. Charger Failure

Indicates the charger is not able to provide the current demanded by the battery and/or load or is providing more current than the charger's control system is commanding. This is typically caused by a charger internal component failure. This alarm does not occur during AC power failures. Activates solid red DC LED. Optional alarm/communications circuit board CHARGER FAIL relay contacts change to Fail state after delay when alarm is assigned to relay contacts.

#### 9.4.7. Overvoltage Shutdown

Indicates that the charger has executed a high voltage shutdown and DC output voltage is above factory alarm setpoint (see Table 17), standard jumper configuration setpoint (see Table 18), or the programmed level if the charger is in Program Mode. The charger disables itself whenever excessive output voltage occurs while the charger is delivering current. The overvoltage shutdown system is protected against nuisance trips and will not execute if the high voltage condition is caused by an external source. Activates solid red DC LED. Optional alarm/communications circuit board OVERVOLTAGE SHUTDOWN relay contacts change to Fail state after delay when alarm is assigned to relay contacts. Reset the charger by removing and replacing any jumper on the circuit board to clear the alarm.

**Table 17 – Factory Jumper Configuration Overvoltage Shutdown Setpoints**

Configuration Code*	Battery Type	Overvoltage Shutdown Setpoint	
		12V	24V
GEN	AGM	17.00	34.01
	FLA	17.00	34.01
	NICD	17.00	34.00
	HCB	17.00	34.01
	Ultracapacitor	17.60	29.20
MAR	VRLA	15.18	30.36
	AGM	15.41	30.82
	NCD	17.00	34.00
NGN	VRLA	15.18	30.36
	AGM	15.41	30.82
	NCD	17.00	34.00
PSP	N/A	13.20	26.40

\*Configuration Code displayed on charger label.

**Table 18 – Standard Jumper Configuration Overvoltage Shutdown Setpoints**

Battery Range	Float Jumper	Overvoltage Shutdown Setpoint
12V	13.3/26.6	17.00
	13.5/27.0	
	14.3/28.6	
	Ultracap Mode	
24V	13.3/26.6	34.00
	13.5/27.0	
	14.3/28.6	
	Ultracap Mode	

#### 9.4.8. Reverse Polarity

Indicates a battery is connected backwards. Charger output is disabled until the condition is corrected. Activates flashing red/yellow DC LED. Optional alarm/communications circuit board REVERSE POLARITY relay contacts change to Fail state after delay when alarm is assigned to relay contacts.

**9.4.9. Low Cranking Voltage**

Indicates the battery voltage is likely to be inadequate to provide engine-cranking capability. Indicates that DC output voltage during a prior cranking event dropped below 6V for a 12V system and below 12V for a 24V system. **This alarm is latching, and must be manually reset by disconnecting both AC and DC power or using optional keypad.** Chargers intended for marine and standby power applications are shipped with the low cranking voltage alarm disabled. Optional alarm/communications circuit board LOW CRANK relay contacts change to Fail state after delay when alarm is assigned to relay contacts.

**9.4.10. Incompatible Battery**

Indicates a 12V battery is connected to a 24V charger. The charger operates for approximately 5 minutes while observing behavior of the DC voltage. If DC voltage behavior is normal the charger will continue charging. If DC voltage behavior is abnormal, as is typical with a battery voltage mismatch, the charger will shut down and lock off after approximately five minutes. Activates flashing yellow DC LED. Optional alarm/communications circuit board INCOMPATIBLE BATTERY relay contacts change to Fail state after delay when alarm is assigned to relay contacts. After correcting mismatched condition, remove and replace any jumper on the main circuit board or cycle power to reset the charger and begin operation. See section [10.6](#) for charging a very low or zero-volt battery.

**9.4.11. Invalid Settings**

Indicates main circuit board output voltage jumpers (see Figure 1) are not valid. Charger output is disabled until the condition is corrected. If the charger is programmed to use custom settings it will enter Program Mode when all jumpers are removed. The invalid jumper alarm will not be active in this case, but will be active if no jumpers are installed and the charger has not been programmed. Activates alternating flashing yellow AC and DC LEDs. Optional alarm/communications circuit board INVALID SETTINGS relay contacts change to Fail state after delay when alarm is assigned to relay contacts.

**9.4.12. J1939 Inactive**

Indicates the charger cannot access the J1939 network when configured to use J1939 communications. This will occur if the charger is not connected to a J1939 network or if the charger cannot claim an address to use on that network. The charger will not use J1939 communications until it can acquire a network address. Optional alarm/communications circuit board J1939 INACTIVE relay contacts change to Fail state after delay when alarm is assigned to relay contacts.

**9.4.13. Modbus Inactive**

Indicates the charger cannot access the Modbus network and is not receiving messages when configured to use Modbus communications. Optional alarm/communications circuit board MODBUS INACTIVE relay contacts change to Fail state after delay when alarm is assigned to relay contacts.

**9.4.14. SENSbus Inactive**

Indicates the charger cannot communicate using SENSbus when load sharing and/or remote accessories are connected. Optional alarm/communications circuit board SENSBUS INACTIVE relay contacts change to Fail state after delay when alarm is assigned to relay contacts.

**9.4.15. Thermal Fold Back**

Indicates charger output is reduced to protect the charger from over-heating damage. The charger will not be able to produce full output until the ambient temperature is lowered. Optional alarm/communications circuit board THERMAL FOLD BACK relay contacts change to Fail state after delay when alarm is assigned to relay contacts.



**9.4.16. No Battery Temperature Sensor**

Indicates disabled or failed remote temperature sensor. Optional alarm/communications circuit board NO BATT TEMP SENSOR relay contacts change to Fail state after delay when alarm is assigned to relay contacts.

**9.4.17. Current Limiting**

Indicates the charger is operating at maximum allowable output, either the maximum current setting or maximum power output (whichever occurs first). Optional alarm/communications circuit board CURRENT LIMIT relay contacts change to Fail state after delay when alarm is assigned to relay contacts.

**9.4.18. Ground Fault**

Indicates a short circuit or high impedance leakage current (greater than 500uA) exists from the charger positive or negative output to ground. To disable the alarm, remove the ground fault jumper from the main circuit board (see Figure 1). Chargers intended for genset applications are shipped with the ground fault alarm disabled via software (even though ground fault jumper is still in place on the main circuit board). Chargers intended for Marine and stationary power applications are shipped with ground fault enabled. When multiple chargers are operated in parallel and the ground fault alarm is desired, physically remove the ground fault jumper on all but one charger (see Figure 1). Optional alarm/communications circuit board GROUND FAULT relay contacts change to Fail state after delay when alarm is assigned to relay contacts.

The RJ-45 port used for communications is not isolated from the charger output. Non-isolated communications equipment/adapters connected to the RJ-45 port may cause a ground fault alarm.

**9.4.19. Low Current**

Indicates current drawn from the charger is below factory alarm setpoint. Chargers intended for genset applications are shipped with the low current alarm disabled. Chargers intended for marine and standby power applications are shipped with the low current alarm set to 2% of the charger's rated output current. Optional alarm/communications circuit board LOW CURRENT relay contacts change to Fail state after delay when alarm is assigned to relay contacts.

**9.4.20. Load Share Fail**

Indicates that chargers connected for load sharing are not sharing the current load. Activates double flashing yellow DC LED. Optional alarm/communications circuit board LOAD SHARE FAIL relay contacts change to Fail state after delay when alarm is assigned to relay contacts.

**9.4.21. AutoBoost Lockout Active**

Indicates the Boost mode time limit has expired and charger has returned to Float mode. Boost mode is disabled until the time limit is reset. The Boost time limit is reset if charger power is cycled, charger is reset by removing and replacing jumpers or an engine crank is detected. The Boost time limit is set to 24 hours by default.

**9.4.22. DC Negative Open**

Indicates an open DC negative output connection when chargers are load sharing. Tighten or make connection to remove alarm. Activates double flashing red DC LED. Optional alarm/communications circuit board DC NEGATIVE OPEN relay contacts change to Fail state after delay when alarm is assigned to relay contacts.

**9.4.23. Address Fault**

Indicates an address fault when more than 30 chargers are connected to load share. Activates double flashing red DC LED. Alarm is not displayed on the optional LCD and cannot be assigned to relay contacts.

#### 9.4.24. Charger Module Fault

Only applicable to multi-charger systems with an optional remote alarm/communications panel accessory. Indicates one or more individual charger(s) are in an alarm state. Activates flashing green/red DC LED. Optional alarm/communications circuit board INDIVIDUAL CHARGER relay contacts change to Fail state after delay when alarm is assigned to relay contacts.

## 10 OPERATION

### 10.1. Charging Algorithms

The charger uses charging algorithms appropriate for different battery types. The charging algorithm for each battery type includes various combinations of Float mode, Dynamic Boost™ mode, and HELIX mode, as described in Table 19. See following sections for descriptions of each charging mode.

**Table 19 – Charging Algorithms**

Battery Type	Charging Algorithm		
	Float Mode	Dynamic Boost Mode	HELIX Mode
FLA for Genset	✓	✓	✓
FLA	✓	✓	
AGM	✓	✓	
NICD	✓	✓	
VRLA	✓		

#### 10.1.1. Recharging Batteries

After a battery has been discharged, the charger will enter Dynamic Boost mode if this mode is enabled (see section [10.3](#)). The charger's output voltage setpoint during Dynamic Boost mode increases to the boost voltage value (see section [10.3](#)). If the battery is deeply discharged, DC voltage will remain below the boost voltage setpoint until the charger's output current drops below its rated maximum. Charging in boost mode continues until the Dynamic Boost control system ends boost mode or the boost time limit expires (boost time limit set to 24 hours by default). After operating in boost mode the charger switches to Float mode. If the charger is configured for flooded lead-acid batteries the charger will engage HELIX mode after operating in Float for a short time.

### 10.2. Float Mode

Float mode is used to maintain stationary batteries and AGM starting batteries in a fully charged state. When the charger is in Float mode the output voltage is maintained at the float voltage setting. See the charger nameplate label or the inside cover label for original factory configuration float value. Float voltage matches jumper value if jumpers are in standard jumper configuration.

**Table 20– Factory Jumper Configuration Float Voltage Settings**

Configuration Code*	Battery Type	Float Voltage	
		12V	24V
GEN	AGM	13.62	27.24
	FLA	13.31	26.62
	NICD	14.30	28.60
	HCB	13.38	26.76
	Ultracapacitor	15.00	25.40
FHP	FLA	13.31	26.62
MAR	VRLA	13.62	27.24
	AGM	13.31	26.62

	NCD	14.30	28.60
NGN	VRLA	13.62	27.24
	AGM	13.31	26.62
	NCD	14.30	28.60
PSP	N/A	12.00	24.00

\*Configuration Code displayed on charger label.

**Table 21 – Standard Jumper Configuration Float Voltage Settings**

Battery Range	Float Jumper	Float Voltage
12V	13.3/26.6	13.3
	13.5/27.0	13.5
	14.3/28.6	14.3
24V	13.3/26.6	26.6
	13.5/27.0	27.0
	14.3/28.6	28.6

### 10.3. Dynamic Boost™ Mode

Dynamic Boost mode utilizes a higher voltage charge to quickly recharge batteries and ensure that all battery cells in a battery string are charged to the same level. Dynamic Boost mode automatically adjusts how long the charger remains in boost mode every recharge cycle. Dynamic Boost automatically adjusts for differing battery sizes, depths of discharge, varying load, battery age and other variables. Dynamic Boost mode safely maximizes recharge performance while cutting risks of both overcharging and undercharging associated with manual or automatic boost timers or earlier generation automatic boost control systems.

Dynamic Boost is automatically used by the charger depending on battery type selected. See the nameplate label or the charger inside cover label for original factory configuration boost value. Flooded lead-acid, absorbed glass mat (AGM) and nickel-cadmium batteries are automatically charged using Dynamic Boost mode when the battery requires it. Charging in boost mode continues until the Dynamic Boost control system ends boost mode or the boost time limit expires. The boost time limit is set to 24 hours by default. Since boost charging is discouraged by most manufacturers of valve-regulated lead-acid (VRLA) batteries used in stationary applications Dynamic Boost mode is disabled when the charger battery type is VRLA. Boost is also disabled when the battery type is set to ultracapacitor.

Relatively high boost voltages are appropriate in applications where rapid charge recovery is essential or required for strict NFPA-20 fire pump or NFPA-110 emergency power system installations. Order chargers from the factory configured for fire pump/emergency power system installations or configure the charger appropriately using the optional keypad or SENS Setup Utility. Use of the optional remote temperature compensation probe is highly recommended to maximize charging performance and optimize battery life.

**Table 22 – Factory Jumper Configuration Boost Voltage Settings**

Configuration Code*	Battery Type	Boost Voltage	
		12V	24V
GEN	AGM	14.32	28.63
	FLA	14.18	28.36
	NICD	15.20	30.40
	HCB	14.40	28.80
	Ultracapacitor	Disabled	Disabled
FHP	FLA	15.70	31.40
MAR	VRLA	Disabled	Disabled

	AGM	13.80	27.60
	NCD	15.20	30.40
NGN	VRLA	Disabled	Disabled
	AGM	13.80	27.60
	NCD	15.20	30.40
PSP	N/A	Disabled	Disabled

\*Configuration Code displayed on charger label.

**Table 23 – Standard Jumper Configuration Boost Voltage Settings**

Battery Range	Float Jumper	Battery Type	Boost Voltage
12V	13.3/26.6	FLA	14.18
		AGM	14.00
		NICD	14.00
		VRLA	Disabled
	13.5/27.0	FLA	14.40
		AGM	14.20
		NICD	14.20
		VRLA	Disabled
	14.3/28.6	FLA	15.20
		AGM	15.20
		NICD	15.20
		VRLA	Disabled
24V	13.3/26.6	FLA	28.36
		AGM	28.00
		NICD	28.00
		VRLA	Disabled
	13.5/27.0	FLA	28.80
		AGM	28.40
		NICD	28.40
		VRLA	Disabled
	14.3/28.6	FLA	30.40
		AGM	30.40
		NICD	30.40
		VRLA	Disabled

#### 10.4. HELIX Mode

HELIX (High Efficiency, Life-eXtending) mode significantly increases the life of flooded lead-acid starting batteries. Battery engineers confirm that continuous flooded SLI (starting batteries) are all designed for vehicle use where they are NOT continuously float charged. Continuous float charging flooded SLI batteries causes these batteries' polyethylene battery separators to oxidize much sooner than would occur in vehicles, where charging is intermittent. Premature separator failure in turn causes earlier failure of the battery than would occur in a vehicle application. Because HELIX allows battery separators to last their entire design life, HELIX also substantially reduces the risk of catastrophic failure of flooded lead-acid batteries.

HELIX is only active when the charger is set at the factory for flooded lead-acid battery type with configuration code "GEN" (see inside cover label for configuration code) or when set for flooded lead-

acid battery type using the Standard Jumper Configuration (see section [6.2](#)). HELIX operates automatically and no configuration is required by the operator. HELIX mode can be disabled using the optional keypad, the SENS Setup Utility, or by selecting a different battery type using the charger jumpers.

HELIX mode adds two DC output voltage settings to the traditional Boost and Float voltages. These are called Eco-Float and Refresh. The Eco-Float voltage is just above battery open circuit voltage, below traditional float. Refresh voltage is approximately halfway between Float and Boost voltage.

When HELIX is operating, the charger spends more than 90% of its operating hours in the Eco-Float mode. In this mode the charger uses less energy and substantially reduces the rate at which water is lost from the battery. If there are no power outages or other battery discharge events the charger periodically transitions from Eco-Float mode to Refresh mode to ensure that the battery remains fully charged. After operating in Refresh mode the charger reverts to Eco-Float mode.

### **10.5. Ultracapacitor Mode**

Ultracapacitor mode is used to charge ultracapacitors rather than batteries. The AC LED will flash green to indicate ultracapacitor mode. The charger output voltage in ultracapacitor mode is 15V for 12V ultracapacitors and 25.4V for 24V ultracapacitors. Dynamic Boost mode is disabled for operation with ultracapacitors.

### **10.6. Charging Low or Zero-volt Batteries**

The charger will initially charge/commission zero-volt or fully discharged batteries without special user intervention. The charger will charge for approximately 5 minutes to determine if the battery voltage will begin to rise. If the voltage rises properly the charger will continue to charge the battery normally using standard output settings (see section [10.7](#) if alternate output settings are required). If the voltage does not rise appropriately within 5 minutes the charger will shut down. This shut down prevents long-term overcharge of a 12V battery in the event of a mismatched battery (a 12V battery is connected to a 24V system). After correcting a mismatched condition, cycle AC and DC power or remove and replace any jumper on the main circuit board to reset the charger and begin operation.

### **10.7. Commissioning Batteries**

Initially charge/commission zero charge batteries with configurable output voltage and current by activating Commissioning Mode from the optional keypad or by using the SENS Setup Utility with the charger in Program Mode. When using the keypad, navigate to the “Battery Set-up” menu to enable commissioning and configure commissioning voltage, current and duration. When using Program Mode and the SENS Setup Utility (because the charger is not equipped with the optional keypad), see section [10.10](#) and the SENS Setup Utility user manual. Commissioning is not available for VRLA, AGM, power supply and ultracapacitor battery types. During commissioning the Over Voltage Shutdown alarm occurs at approximately 102% of the commissioning charge voltage and temperature compensation is not active. After commissioning completes, the charger will automatically revert to the settings configured for normal charging, including temperature compensation and Over Voltage Shutdown alarm.

### **10.8. Battery Check**

Run a Battery Check test to determine if a battery can support a load. Battery Check will reduce charger output voltage to a configurable backstop level to permit the battery to support the load. Activate a Battery Check using the optional keypad. Navigate to the “Battery Check” menu to enable a Battery Check and configure battery check minimum voltage and duration. Upon completion of the test, the LCD will display whether the test passed or failed for ten seconds or until the “Enter” key is pressed. If the audible alarm is enabled, a single beep occurs when the battery check results are displayed. Schedule a Battery Check to run automatically by setting the Scheduled Battery Check interval in the “Battery Check” menu. An in-progress Battery Check activates a fast flashing green DC LED. Battery Check failure activates a fast flashing yellow DC LED. Optional alarm/communications circuit board BATTERY CHECK relay contacts change to Fail state after delay when alarm is assigned to relay contacts.

Clear a failed Battery Check alarm using the keypad by scrolling to the “Alarms & Settings” menu then selecting the “Battery Check” option and pressing the UP arrow.

**IMPORTANT:** A load less than 3% of the charger maximum current rating may cause inaccurate battery check results. If the system load is typically lower than 3% disable the Scheduled Battery Check feature. Battery Check will not indicate whether a battery is healthy enough to start a generator or engage switchgear relays for chargers in typical genset or switch gear applications without a continuous current load.

**10.9. Keypad Operation**

Chargers and accessories equipped with the optional front panel keypad provide the ability to adjust charger settings without the SENS Setup Utility.

**10.9.1. Security Code Protection**

Chargers with the optional keypad are security code protected to ensure only authorized personnel may adjust charger settings. The default security code is 000000 meaning security code is not enabled. Change the security code to a unique value by scrolling to the “Service Tools” menu and then the “Change Security Code” option. Contact SENS Customer Service if a custom password is lost or forgotten (800-742-2326 or www.sens-usa.com).

**10.9.2. Menu Navigation**

Use the keypad to scroll through settings to view and adjust. The keypad provides X-Y navigation with main fields up and down, and details within each field left and right (see Figure 14). Press the up and down arrow keys to scroll through main menu options. Press the left and right arrow keys to scroll through data available within each menu. Value adjustments are made with the up and down arrow keys. Press center Enter key to return to main fields. Press center Enter key twice to return to Home screen.

**Figure 14 – Menu Navigation**

Step 1	↑ or ↓ for main fields
Step 2	← or → for details within each main field
Step 3	↑ or ↓ to adjust values
Step 4	↶ to return to main fields
Step 5	↶ to return to Home screen

**10.9.3. Menu Options**

Input, output, temperature and alarm status are displayed on the front panel LCD by default. Press the UP or DOWN arrow to access additional menus as described below. If an option described below is not displayed it is likely because the option or an associated parameter is not set to active or the “UI Access Control” is set to a restricted state. Absolute maximum voltage limits apply to all output and alarm settings. A message is displayed indicating an adjustment is limited due to settings conflict.

Main Menus <i>(Press up and down arrows to scroll through Main Menu Options)</i>	Configurable/Viewable Parameters <i>(Press left and right arrows to scroll through choices within each Menu Option)</i>	Parameter Descriptions
Meters	AC Input	AC input voltage and frequency
	DC Output <i>(voltage)</i>	DC output voltage and current
	DC Output <i>(power)</i>	DC output watts and % of rated output being

		provided
	Battery Temp.	Temperature at battery if a remote temperature sensor is connected
	Internal Temp.	Temperature inside charger
Boost Settings	Auto Boost Delay	Adjust amount of time from 0 to 5 minutes to delay before entering Boost mode after power is cycled or battery type is changed
	Auto-Boost	Enable or disable Dynamic Boost mode
	Auto Boost Limit	Adjust the maximum amount of time charger will be in Dynamic Boost mode from 1 to 100 hours. The Boost time limit is reset if charger power is cycled or an engine crank is detected.
	Boost Duration	Adjust amount of time charger will be in scheduled periodic Boost mode from 1 to 100 hours. The Boost timer is reset if charger power is cycled
	Scheduled Boost	Adjust amount of time between periodic scheduled Boost events from 1 to 180 days. Set to OFF to disable.
	Run Timed Boost	Start or stop a manual Boost cycle. Will operate in Boost mode until the Boost Duration expires.
	Output Settings	Float Voltage
Boost Voltage		Adjust output Boost voltage from 8 to 34V, must be same or greater than Float setting, must not be greater than 166% of Float setting
HELIX-EcoFloat		Enable or disable HELIX mode
Current Limit		Adjust current limit from 25% to 100% of nominal current rating. Charger current limit is governed to this value.
Temp. comp./°C		Adjust temperature compensation slope from 0 to -0.30%/°C
Alarms & Settings		Low Cranking
	Battery Check	Press UP arrow to reset/clear Battery Check alarm
	Alarm Delay Time	Adjust amount of time to delay activation of alarms after alarm event takes place from 5 to 60 seconds. Alarm/comms circuit board alarm relay contacts and alarms on communications ports are delayed; LED alarm indication is not delayed.
	Ground Fault Alarm	Enable or disable ground fault alarm
	Low Crank Alarm	Adjust setpoint to trigger Low Crank alarm from 6V to 98% of Float, must be at least 2% less than Float setting
	End Discharge	Adjust setpoint to trigger Battery End-of-Discharge alarm, must be less than Low DC setting
	Low DC Voltage	Adjust setpoint to trigger Low DC voltage alarm, must be greater than End Discharge

		setting and less than Battery Discharging setting
	Batt Discharging	Adjust setpoint to trigger Battery Discharging alarm, must be between Low DC setting and 98% of Float setting or Eco-Float setting when HELIX is active
	High DC Voltage	Adjust setpoint to trigger High DC voltage alarm from 8 to 35V, must be greater than Boost by 2% of Float setting, must be less than 40% higher than Boost setting
	Overvolt Fault	Adjust setpoint to trigger Over Voltage Shutdown alarm from 8 to 35V, must be greater than High DC setting
	Low Current	Adjust setpoint to trigger Low Current alarm from 0% to 50% of nominal current
Battery Set-up	Battery Select ( <i>type</i> )	Select type of battery to be charged - flooded lead-acid, AGM, nickel-cadmium VRLA, power supply or ultracapacitor.
	Battery Select ( <i>cells</i> )	Adjust number of series cells in battery string
	Batt Commission ( <i>voltage</i> )	Adjust battery commissioning output voltage from float voltage to 34V, must be greater than or equal to Float voltage
	Batt Commission ( <i>current</i> )	Adjust battery commissioning output current from 5% to 100% of nominal current rating
	Batt Commission ( <i>duration</i> )	Adjust battery commissioning hours from 1 to 120 hours
	Batt Commission ( <i>enable</i> )	Start or stop commissioning cycle. Charger will deliver commissioning voltage and current until commissioning hours expire.
	Restore Factory Default Settings	Restore settings to factory configuration
Other Settings	Relay Assignment	Selection alarm relay assignments based on application (see Tables 7-9)
	Audio Alarm Mode	Mute or enable audible alarm indication
	Keypad Click	Mute or enable audible beep upon keypad button press
	DC Output #A	Disable for stand-alone chargers
	DC Output #B	Disable for stand-alone chargers
	DC Output #C	Disable for stand-alone chargers
	DC Output #D	Disable for stand-alone chargers
	Set Output	Assign to Default for stand-alone chargers
Battery Check	Battery Check	Start or stop a manual Battery Check.
	Batt Check Time	Adjust amount of time to run Battery Check from 1 to 60 minutes
	Batt Check Vmin	Adjust minimum voltage allowed during Battery Check test, must be greater than End-of-Discharge voltage and less than 98% Float voltage
	Sched Batt Check	Adjust amount of time between scheduled Battery Check tests from 1 to 90 days
	Next Sched Batt Check	View time until next scheduled Battery Check test
Service Tools	Relay Test	Press UP arrow to set all alarm relays and DOWN arrow to clear all relays
	Display Test	Press UP arrow to set all LCD segments black and DOWN arrow to clear all LCD segments



	Internal Voltages	View internal rail voltages for troubleshooting purposes. Correct values are approximately 3.3V, 5V and 11V.
	UI Access Control	Select allowed user interface access. Access options include read-only viewing, normal access or full access adjustments for advanced users.
	Change Security Code	Change security code to desired 6 digits. The default security code is 000000 (disabled). Upon entering a security code, the display will automatically prompt user for the code to access protected menus. Menus are protected depending on configured level of access (see UI Access Control definitions above).
	Relock Access	Exit Service Mode and relock access
I-O Bus Settings	I-O Configuration	Select RTU or ASCII Modbus (RS-485). Set to OFF to disable Modbus communications.
	I-O Configuration I-O Address	Adjust Modbus slave address from 1 to 255 (RS-485). Set to OFF to disable Modbus communications.
	I-O Configuration Parity Bit	Set Modbus (RS-485) parity to none, even or odd
	I-O Configuration Baud Rate	Adjust Modbus (RS-485) baud rate, 57.6 Kbps maximum
	Modbus Configuration Write	Enable or disable write access via Modbus
	J1939 Configuration BCH1 Output	Assign charger output for J1939 battery charger address to 1
	J1939 Configuration BCH2 Output	Assign charger output for J1939 battery charger address 2
	J1939 Configuration Veh Sys Instance	Adjust J1939 Vehicle System Instance from 0 to 15
	J1939 Configuration Funct Instance	Adjust J1939 Function Instance from 0 to 31
	J1939 Configuration ECU Instance	Adjust J1939 ECU Instance from 0 to 7
	J1939 Configuration Extended Status	Enable or disable receiving extended J1939 data
Unit Information	Serial No.	Charger serial number
	Revision	Software revision currently loaded on alarms/comms circuit board
	Copyright	MicroGenius copyright year

## 10.10. Program Mode

Use the SENS Setup Utility to program the charger with custom settings. Custom configuration is typically completed by OEMs, qualified dealers/distributors, and packagers. The setup utility allows configuration of all charger settings including alarm relay assignments. Removing all jumpers enables Program Mode. If the charger has not been specially programmed, removing all jumpers will result in an INVALID SETTINGS error state and the charger will not produce output.

### 10.10.1. Connect SENSbus Adapter

Communication between a computer and the charger/system using the SENS Setup Utility requires connection of the SENSbus Adapter (shipped with SENS Setup Utility kit). Connect the provided USB cable from the USB port on a PC to the SENSbus Adapter port labeled "USB." Connect the provided network cable from the SENSbus Adapter RJ-45 port labeled "SENSbus" to the RJ-45 port on the charger main circuit board. Two RJ-45 ports are provided on the main

circuit board (see Figure 11 for location in charger and Figure 13 for detail). The ports are in parallel and either port may be used for the SENSbus Adapter connection. See the SENS Setup Utility user manual for information on configuring the charger.

### 10.11. Temperature Compensation

The charger is temperature compensated to match the negative temperature coefficient of the battery. When temperature compensation is active, the output voltage will increase slightly as temperature decreases, decrease as temperature increases, and is clamped at 0°C (32°F) and +50°C (122°F) to protect against extremely high or low output voltage (see Figure 15).

The charger automatically includes local temperature compensation using an internal on-board sensor. Remote temperature compensation is enabled when an optional external sensor is located at the batteries (see section 7.6 for connections). Remote temperature compensation is required for ultracapacitor charging and should be used in applications where battery and charger are located in different ambient conditions. Temperature Compensation is set to a slope of -0.18% per °C by default for operation with batteries. The temperature Compensation slope for ultracapacitors is set by the factory and is not adjustable. Temperature compensation is disabled by connecting a short across the remote temperature sensor terminal block on the main circuit board, using the optional keypad or by setting the temperature compensation slope to zero using the SENS Setup Utility. If the optional LCD is included, the temperature present at a sensor (local or remote) is displayed. Actual battery temperature is only displayed if the optional remote temperature sensor is connected to the charger and placed at the batteries.

Figure 15 – Example Temperature Compensation Curves

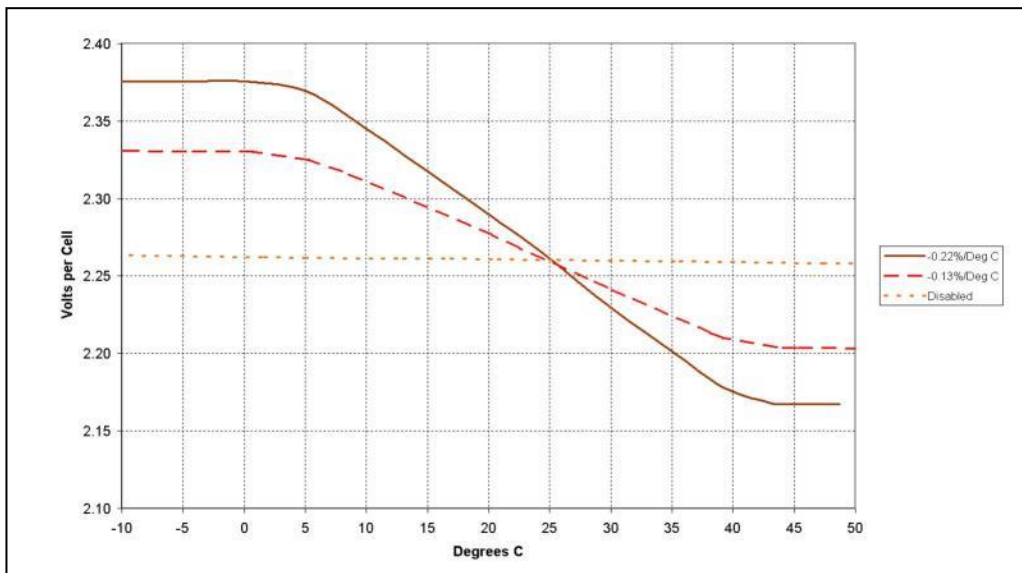

### 10.12. Load Share Charger Operation

Multiple chargers may be connected in parallel to provide charger redundancy and increased charging current. Up to 30 chargers may be connected in parallel for load sharing. Load sharing chargers are fault tolerant; one charger failure will not cause failures in paralleled chargers.

#### 10.12.1. Load Sharing and Synchronization

Connection of a network cable between chargers using RJ-45 connectors (see section 7.8) automatically initiates load sharing synchronization of operating modes. Chargers will share the current load within  $\pm 10\%$ . Remove the ADD jumper from the main circuit board of any charger connected to load share (see Figure 8). For proper load share operation, a 120-ohm terminator is required at the ends of the bus. Chargers intended for load sharing must be configured with

the same output settings in order to load share properly. A charger in a multi-charger load sharing system with different output settings will not load share properly. The LOAD SHARE FAIL alarm will occur any time a charger is unable to load share. If a charger in a multi-charger load sharing system fails or is disconnected the remaining chargers will still load share and ignore the faulted charger. Each load sharing charger will alarm independently using individually configured alarm setpoints.

If the optional alarm/communications circuit board is included the output voltage and current of the individual charger will be shown on the LCD. If an optional remote alarm/communications panel accessory (not included internal to charger) is connected it will display only the system output voltage and current. An alarm/communications circuit board that is configured for an individual charger can be set to show system information by using the SENS Setup Utility.

Chargers connected in parallel without the load sharing network cable will operate but without synchronization. Current is not shared between chargers, Boost and HELIX modes are not synchronized and the system voltage is not displayed on the optional LCD. The chargers must be set for the same voltage range (12V or 24V) and Float voltage. When load sharing is disabled boost mode should be disabled on all but one charger to avoid conflicts between chargers. As a result, redundancy of Boost output voltage is not included when load sharing is not employed.

### 10.13. Remote Alarm/Communications Panel Accessory

The optional remote alarm/communications panel accessory provides the ability to adjust and communicate with multiple chargers using one external device. Connection of a network cable between the accessory and charger(s) using RJ-45 connectors (see section [7.9](#)) automatically initiates communication. For proper operation, a 120-ohm terminator is required at the ends of the bus. Adjust configuration and view status using the front panel keypad and display. See section [10.9](#) for keypad operation.

## 11 J1939 COMMUNICATIONS

---

See data messages below for read-only information available using J1939. Each charger automatically broadcasts a data message once per second after it has joined the J1939 network. Charger operation parameters may not be configured using J1939 communications.

In most cases, charger default J1939 settings are sufficient to automatically begin using J1939 communications after connecting the charger to the network. Use the SENS Setup Utility to adjust J1939 settings (e.g. baud rate, vehicle system instance, etc.) if required.

### 11.1. J1939 Data Messages

J1939 Data	Bits	Details
Battery Charger State	0-3	0 = OFF, 1 = boost charge, 2 = float charge, 13 = battery failure/too hot/cold to charge, 14 = charger failure, 15 = no status available
AC Power Line State	4-5	0 = AC OFF, 1 = AC ON, 2 = sensing error, does not indicate power out of specification, 3 = no status available
Thermal Limit Alarm*	6-7	0 = OK, 1 = Fail, 2 = sensor failure, 3 = no status available
Output Voltage	8-23	0 to 3212.75V in 0.05V increments, 0xFFFF = data not available, 0xFEFF = hardware error
Output Current	24-39	-1600.00 to +1612.75A in 0.05A increments, 0xFFFF = data not available, 0xFEFF = hardware error
High DC Voltage Alarm*	42-43	0 = OK, 1 = Fail, 2 = sensor failure, 3 = no status available

Low DC Voltage Alarm*	44-45	0 = OK, 1 = Fail, 2 = sensor failure, 3 = no status available
Low Cranking Voltage Alarm*	46-47	0 = OK, 1 = Fail, 2 = sensor failure, 3 = no status available
Invalid Settings Alarm*	48-49	0 = OK, 1 = Fail, 2 = sensor failure, 3 = no status available

\*Optional, must enable SENS data extensions using SENS Setup Utility

## 12 MODBUS COMMUNICATIONS

Modbus communications settings must be configured using the optional keypad or SENS Setup Utility prior to executing communications (default settings provided below, but SENS Setup Utility required to configure Slave Address). Modbus is provided over RS-485 using RTU or ASCII mode.

### 12.1. Modbus Default Settings

Setting	Value
Configuration	RTU
Baud Rate	19200
Data Bits	8
Parity	Even
Stop Bits	1
Slave Address	10

### 12.2. Modbus Holding Registers

Address High		Address Low		Name	Description	Units	Scale Factor
Decimal	Hex	Decimal	Hex				
0	0x000	1	0x001	System Serial Number	Serial Number of System the device was built into and shipped part of	Num	1
2	0x002	3	0x003	Program Revision	Version of the main program	Num	1
4	0x004	5	0x005	Bootloader Version	Version of bootloader	Num	1
6	0x006	7	0x007	Type	Device type	Enum	1
8	0x008	9	0x009	Serial	Serial Number of the Device	Num	1
10	0x00A	11	0x00B	Build Date	Year (16bit), month(8bit),day(8bit)	Num	1
12	0x00C	13	0x00D	Model Num 1_4	Model number character	bit	1
14	0x00E	15	0x00F	Model Num 5_8	Model number character	bit	1
16	0x010	17	0x011	Model Num 9_12	Model number character	bit	1
18	0x012	19	0x013	Model Num 13_16	Model number character	bit	1
20	0x014	21	0x015	Model Num 17_20	Model number character	bit	1
22	0x016	23	0x017	Model Num 21_24	Model number character	bit	1
24	0x018	25	0x019	Model Num 25_28	Model number character	bit	1
26	0x01A	27	0x01B	Model Num 29_32	Model number character	bit	1
28	0x01C	29	0x01D	Watt Minutes High	For Odometer	bit	1
30	0x01E	31	0x01F	Watt Minutes Low	For Odometer	bit	1
32	0x020	33	0x021	Minutes in Charge High	For Odometer	bit	1
34	0x022	35	0x023	Minutes in Charge Low	For Odometer	bit	1
36	0x024	37	0x025	Number of Cranks Detected	Number of times the crank logger has been tripped	Num	1
38	0x026	39	0x027	Number of Cranks Under Threshold	Number of times the crank logger has detected a bad battery	Num	1
40	0x028	41	0x029	Autoboost Lockout Duration	Autoboost Lockout Duration	Num	60
64	0x040	65	0x041	Default Output Status	Current State of the charger (see Status Definition below)	Bits	1
66	0x042	67	0x043	Default Output Alarms	Alarm status bits (see Alarm Bit Definition below)	Bits	1

Address High		Address Low		Name	Description	Units	Scale
68	0x044	69	0x045	Default Output Batt Voltage	Voltage currently being supplied by the charger to the battery	V	32768
70	0x046	71	0x047	Default Output Current	Current currently being supplied by the charger to the battery	A	32768
72	0x048	73	0x049	Default Output Power	Power currently being supplied by the charger	W	32768
74	0x04A	75	0x04B	Default Output Factory Float Setting	Float Cell Voltage set at Factory	V/cell	32768
76	0x04C	77	0x04D	Default Output Factory Boost Setting	Boost Cell Voltage set at Factory	V/cell	32768
78	0x04E	79	0x04F	Default Output Remote Temp	Remote temp sense temperature in 0.0°C	°C	32768
80	0x050	81	0x051	Default Output Internal Temp	Ambient air temperature near charger input connectors (tp 1)	°C	32768
82	0x052	83	0x053	Default Output Boost Elapsed Time	Boost time	Sec	1
84	0x054	85	0x055	Default Output Periodic Boost Period	Interval between periodic boost events (0 = disabled)	Sec	1
86	0x056	87	0x057	Default Output AC Line Frequency	AC Line Frequency	Hz	10
88	0x058	89	0x059	Default Output AC Line Voltage 1	AC Line 1 Voltage	V	32768
90	0x05A	91	0x05B	Default Output AC Line Current 1	AC Line 1 Current	A	32768
92	0x05C	93	0x05D	Default Output AC Line Voltage 2	AC Line 2 Voltage (Not applicable to single phase chargers)	V	32768
94	0x05E	95	0x05F	Default Output AC Line Current 2	AC Line 2 Current (Not applicable to single phase chargers)	A	32768
96	0x060	97	0x061	Default Output AC Line Voltage 3	AC Line 3 Voltage (Not applicable to single phase chargers)	V	32768
98	0x062	99	0x063	Default Output AC Line Current 3	AC Line 3 Current (Not applicable to single phase chargers)	A	32768
100	0x064	101	0x065	Default Output Battery Check Duration	Duration of battery check	Sec	1
102	0x066	103	0x067	Default Output Battery Check Interval	Interval between scheduled automatic battery checks	Sec	1
104	0x068	105	0x069	Default Output Number of Chargers	Number of chargers detected on SENSbus, 0 - 30	Num	1
106	0x06A	107	0x06B	Default Output Redundancy Level	Number of redundant output chargers	Num	1
108	0x06C	109	0x06D	Default Output Extended Status	Current state of alarm/comms circuit board (see Extended Status Bit Definition)	bit	1
128	0x080	129	0x081	Default Output Maximum Power	Maximum rated power	V/Cell	32768
130	0x082	131	0x083	Default Output Maximum Voltage	Maximum rated voltage in x.xx V	V/Cell	32768
132	0x084	133	0x085	Default Output Maximum Current	Maximum rated current in x.xx A	A	32768
134	0x086	135	0x087	Default Output Program Float Setting	Float Cell Voltage used in Program Mode	V/Cell	32768
136	0x088	137	0x089	Default Output Program Boost Setting	Boost Cell Voltage used in Program Mode	V/Cell	32768
138	0x08A	139	0x08B	Default Output Program	Mode callouts for Program Mode	Custom	1

Address High		Address Low		Name	Description	Units	Scale
				Mode	setting (battery type... etc.)		
140	0x08C	141	0x08D	Default Output Program Cell Count	Number of cells set in Program Mode	Cells	32768
142	0x08E	143	0x08F	Default Output Program Temp comp slope	In 0.xx°C per output volt x -1	°C/V	32768
144	0x090	145	0x091	Default Output Low DC Program	Alarm setpoint for low DC (used for Program Mode setting)	V/Cell	32768
146	0x092	147	0x093	Default Output Low Crank Program	Alarm setpoint for low Crank (used for Program Mode setting)	V/Cell	32768
148	0x094	149	0x095	Default Output Low Current Program	Alarm setpoint for low Current(used for Program Mode setting)	A	32768
152	0x098	153	0x099	Default Output High DC Program	Alarm setpoint for high DC (used for Program Mode setting)	V/Cell	32768
154	0x09A	155	0x09B	Default Output OVSD Program	Alarm setpoint for OVSD (used for Program Mode setting)	V/Cell	32768
156	0x09C	157	0x09D	Default Output Batt Discharge Program	Alarm setpoint for Batt Discharge (used for Program Mode setting)	V/Cell	32768
158	0x09E	159	0x09F	Default Output Batt End Discharge Program	Alarm setpoint for End Discharge (used for Program Mode setting)	V/Cell	32768
160	0x0A0	161	0x0A1	Default Output Program Boost Time Limit	Boost time limit (used for Program Mode setting)	Hr	3600
162	0x0A2	163	0x0A3	Default Output Current Limit Setting	Current Limit setpoint in % of output current as a 10 bit value	% Rated A	32768
164	0x0A4	165	0x0A5	Default Output Helix Float Time	Helix Float Time	Hr	3600
166	0x0A6	167	0x0A7	Default Output Helix Refresh Time	Helix Refresh Time	Hr	3600
168	0x0A8	169	0x0A9	Default Output Helix Eco Time	Helix Eco Time	Hr	3600
170	0x0AA	171	0x0AB	Default Output Periodic Boost Time	Interval between scheduled Periodic Boost	Days	86400
172	0x0AC	173	0x0AD	Default Output Battery Check Voltage Setting	Battery check failure threshold	V/Cell	32768
174	0x0AE	175	0x0AF	Default Output Battery Check Interval	Interval between scheduled automatic battery checks	Days	86400
176	0x0B0	177	0x0B1	Default Output Battery Check Duration	Duration of battery check	Min	60
178	0x0B2	179	0x0B3	Default Output Commissioning VPC	Commissioning VPC	V/Cell	32768
180	0x0B4	181	0x0B5	Default Output Commissioning Duration	Commissioning Duration	Hr	3600
182	0x0B6	183	0x0B7	Default Output Commissioning A	Commissioning Amps	A	32768
184	0x0B8	185	0x0B9	Default Output Rated Power	Output Rated Power	W	32768
186	0x0BA	187	0x0BB	Default Output Rated Current	Output Rated Current	A	32768
188	0x0BC	189	0x0BD	Default Output Periodic Boost Duration	Periodic Boost Duration	Bits	3600
190	0x0BE	191	0x0BF	Default Output Min Allowed Voltage Setting	Min Allowed Voltage Setting	V/Cell	32768

### 12.3. Status Definition

Value		Name	Description
Decimal	Hex		
0	0x00	Startup	Turning on or in bootloader
1	0x01	Idle	Charger is "off"
2	0x02	Boost	Boost Charge Mode
3	0x03	Slave	Following another unit's commands
4	0x04	Float	Float Charge Mode
5	0x05	Low Battery Charge	Charging but output is below low battery threshold
6	0x06	AC Not Working	AC not detected or out of range for operation
7	0x07	Invalid Settings	The charger is locked out because settings are invalid
8	0x08	Reverse Polarity	The charger is off due to a reverse polarity condition
9	0x09	Reserved For Future Use	Reserved for Future Use
10	0x0A	Low Battery Error	Charger was not able to bring up a low battery in the required time
11	0x0B	Over Current Protection	Charger has detected an over current condition
12	0x0C	Charger Fail	Charger has detected a failure and has locked itself off
13	0x0D	SENSbus Error	Charger could not find a valid SENSbus address and has shutdown
14	0x0E	HELIX Eco	HELIX Eco-Float Charge Mode
15	0x0F	HELIX Refresh	HELIX Refresh Charge Mode
16	0x10	Periodic Boost	Scheduled or Forced Time controlled Boost
17	0x11	Battery Check	Scheduled or Forced Battery Check Routine
18	0x12	Commission Charge	Timed Commission Charge

### 12.4. Alarm Bit Definition

Bit Address		Name	Description
Decimal	Hex		
0	0x00	Alarm AC Fail	Charger does not have usable AC input
1	0x01	Alarm High DC	Charger output exceeds alarm threshold
2	0x02	Alarm Low DC	Charger output below alarm threshold
3	0x03	Alarm Charger Fail	Charger not operating because of an internal failure
4	0x04	Alarm Over Voltage Shutdown	Charger disabled by selective overvoltage shutdown
5	0x05	Alarm Reverse Polarity	Charger disabled because battery polarity is reversed
6	0x06	Alarm Low Cranking	Low cranking voltage event has been detected
7	0x07	Alarm Incompatible Battery	Charger disabled because it does not match battery (12V vs. 24V)
8	0x08	Alarm Invalid Settings	Charger disabled because jumper setting is not correct
9	0x09	Alarm J1939 Inactive	J1939 enabled, but no bus access (did not obtain an address)
10	0x0A	Alarm Thermal Foldback	Available output is reduced because of high temperature
11	0x0B	Alarm No Temperature Probe	Battery temperature probe is not connected
12	0x0C	Alarm Current Limiting	Operating in current limit mode (below output voltage set point)
13	0x0D	Alarm Ground Fault Positive	Ground fault alarm enabled and positive ground detected
14	0x0E	Alarm Low Current	Low current alarm enabled and output below alarm threshold
15	0x0F	Alarm Load Share Fault	Charger fails to provide its share of the output current
16	0x10	Alarm J1939 Inactive	J1939 enabled, but no bus access (did not obtain an address)
17	0x11	Alarm MODbus inactive	MODbus enabled, but no network activity detected
18	0x12	Alarm SENSbus Inactive	Display board is not receiving any charger data

Bit Address		Name	Description
19	0x13	Alarm Battery On Discharge	Battery in range where discharge occurs (below open circuit voltage)
20	0x14	Alarm Battery End Discharge	Battery voltage below safe discharge range threshold
21	0x15	Alarm Ground Fault Negative	Ground fault alarm enabled and negative ground detected
22	0x16	Alarm DC Negative Open	Charger disabled because common negative lead is open
23	0x17	Alarm Spare 23	Spare bit, available for future use, reads false (Off, 0)
24	0x18	Alarm Spare 24	Spare bit, available for future use, reads false (Off, 0)
25	0x19	Alarm Load Disconnect	Load relay open: set at "end discharge", clear when not "on discharge"
26	0x1A	Alarm Individual Unit Fault	Alarm flag 32-54 active for one, but not all, chargers in any Output
27	0x1B	Alarm Battery Check	Battery check failed
28	0x1C	Alarm Circuit Breaker	Circuit breaker monitor contacts are active (if present)
29	0x1D	Alarm Surge Arrestor	Surge arrestor monitor contacts are active (if present)
30	0x1E	Alarm Load Relay Control	Enable load control relay (if present)
31	0x1F	Alarm Vent Fan Control	Enable battery vent fan (if present)

### 12.5. Extended Status Bit Definition

Bit Address		Name	Description
Decimal	Hex		
0	0x00	Output Idle	Charger output is disabled
1	0x01	Slave Mode	Charger operating in slave mode (should not occur on system displays)
2	0x02	Helix Float Charge	Charger operating in Helix float state
3	0x03	Float Charge	Charger operating in float state
4	0x04	Helix Refresh Charge	Charger operating in Helix refresh state
5	0x05	Automatic Boost Charge	Charger operating in automatic boost state
6	0x06	Timed Boost Charge	Charger operating in timed (manual) boost state
7	0x07	Periodic Boost Charge	Charger operating in scheduled (periodic) boost state
8	0x08	Battery Check Active	Battery check cycle in progress
9	0x09	Commissioning Charge	Charger operating in commissioning charge state
10	0x0A	Spare Bit 10	Not used, reads false (Off, 0)
11	0x0B	Spare Bit 11	Not used, reads false (Off, 0)
12	0x0C	Spare Bit 12	Not used, reads false (Off, 0)
13	0x0D	Spare Bit 13	Not used, reads false (Off, 0)
14	0x0E	Spare Bit 14	Not used, reads false (Off, 0)
15	0x0F	Spare Bit 15	Not used, reads false (Off, 0)
16	0x10	Spare Bit 16	Not used, reads false (Off, 0)
17	0x11	Three Phase Input	Charger has three phase input
18	0x12	Battery Temperature Valid	Have valid remote temperature sensor reading
19	0x13	Scheduled Equalize Enabled	Scheduled boost charge cycles enabled
20	0x14	Scheduled Battery Check Enabled	Scheduled battery check cycles enabled
21	0x15	UI Passive	UI access mode is passive (no keypad)
22	0x16	OBS UI Hidden Mode	Obsolete, reads false (Off, 0)
23	0x17	UI Monitor Mode	UI access mode is monitor only (no adjustments)
24	0x18	UI Normal Mode	UI access mode is normal (standard adjustments)
25	0x19	UI Advanced Mode	UI access mode is advanced (all adjustments, including battery type and system configuration)
26	0x1A	UI Access Code Unlocked	Unlocked by UI security code (can change UI access mode and security code settings)
27	0x1B	Spare Bit 27	Not used, reads false (Off, 0)
28	0x1C	Spare Bit 28	Not used, reads false (Off, 0)



Bit Address		Name	Description
Decimal	Hex		
29	0x1D	Spare Bit 29	Not used, reads false (Off, 0)
30	0x1E	Multiple Outputs	More than one output is present
31	0x1F	System Display Board	Display board monitors all units on SENSbus (not just those in same unit)

## 12.6. Writable Control Flags (Coils)

Single coil writes: 0xFF00 for ON, 0x0000 for OFF

Multiple coil writes: 1 for ON, 0 for OFF

Address		Description	Details
Decimal	Hex		
0	0x000	Start/stop manual boost, Default Output	ON to start, OFF to stop
1	0x001	Reset periodic boost charge schedule	ON to reset schedule, OFF is no-op
2	0x002	Start/stop battery check, Default Output	ON to start, OFF to stop
3	0x003	Reset periodic battery check schedule	ON to reset schedule, OFF is no-op
4	0x004	Clear battery check failure, Default Output	ON to reset alarm, OFF is no-op
5	0x005	Clear low cranking failure, Default Output	ON to reset alarm, OFF is no-op
16	0x010	Start/stop manual boost, Channel A	ON to start, OFF to stop
17	0x011	Reset periodic boost charge schedule	ON to reset schedule, OFF is no-op
18	0x012	Start/stop battery check, Channel A	ON to start, OFF to stop
19	0x013	Reset periodic battery check schedule	ON to reset schedule, OFF is no-op
20	0x014	Clear battery check failure, Channel A	ON to reset alarm, OFF is no-op
21	0x015	Clear low cranking failure, Channel A	ON to reset alarm, OFF is no-op
32	0x020	Start/stop manual boost, Channel B	ON to start, OFF to stop
33	0x021	Reset periodic boost charge schedule	ON to reset schedule, OFF is no-op
34	0x022	Start/stop battery check, Channel B	ON to start, OFF to stop
35	0x023	Reset periodic battery check schedule	ON to reset schedule, OFF is no-op
36	0x024	Clear battery check failure, Channel B	ON to reset alarm, OFF is no-op
37	0x025	Clear low cranking failure, Channel B	ON to reset alarm, OFF is no-op
48	0x030	Start/stop manual boost, Channel C	ON to start, OFF to stop
49	0x031	Reset periodic boost charge schedule	ON to reset schedule, OFF is no-op
50	0x032	Start/stop battery check, Channel C	ON to start, OFF to stop
51	0x033	Reset periodic battery check schedule	ON to reset schedule, OFF is no-op
52	0x034	Clear battery check failure, Channel C	ON to reset alarm, OFF is no-op
53	0x035	Clear low cranking failure, Channel C	ON to reset alarm, OFF is no-op
64	0x040	Start/stop manual boost, Channel D	ON to start, OFF to stop
65	0x041	Reset periodic boost charge schedule	ON to reset schedule, OFF is no-op
66	0x042	Start/stop battery check, Channel D	ON to start, OFF to stop
67	0x043	Reset periodic battery check schedule	ON to reset schedule, OFF is no-op
68	0x044	Clear battery check failure, Channel D	ON to reset alarm, OFF is no-op
69	0x045	Clear low cranking failure, Channel D	ON to reset alarm, OFF is no-op

FreeModbus Library: A portable Modbus implementation for Modbus ASCII/RTU. Copyright (c) 2006 Christian Walter <[wolti@sil.at](mailto:wolti@sil.at)>. All rights reserved.

Redistribution and use in source and binary forms, with or without modification, are permitted provided that the following conditions are met:

1. Redistributions of source code must retain the above copyright notice, this list of conditions and the following disclaimer.
2. Redistributions in binary form must reproduce the above copyright notice, this list of conditions and the following disclaimer in the documentation and/or other materials provided with the distribution.
3. The name of the author may not be used to endorse or promote products derived from this software without specific prior written permission.

THIS SOFTWARE IS PROVIDED BY THE AUTHOR "AS IS" AND ANY EXPRESS OR IMPLIED WARRANTIES, INCLUDING, BUT NOT LIMITED TO, THE IMPLIED WARRANTIES OF MERCHANTABILITY AND FITNESS FOR A PARTICULAR PURPOSE ARE DISCLAIMED. IN NO EVENT SHALL THE AUTHOR BE LIABLE FOR ANY DIRECT, INDIRECT, INCIDENTAL, SPECIAL, EXEMPLARY, OR CONSEQUENTIAL DAMAGES (INCLUDING, BUT NOT LIMITED TO, PROCUREMENT OF SUBSTITUTE GOODS OR SERVICES; LOSS OF USE, DATA, OR PROFITS; OR BUSINESS INTERRUPTION) HOWEVER CAUSED AND ON ANY THEORY OF LIABILITY, WHETHER IN CONTRACT, STRICT LIABILITY, OR TORT (INCLUDING NEGLIGENCE OR OTHERWISE) ARISING IN ANY WAY OUT OF THE USE OF THIS SOFTWARE, EVEN IF ADVISED OF THE POSSIBILITY OF SUCH DAMAGE.

## 13 TROUBLESHOOTING/ERROR CODES

### 13.1. Configuration Error Codes

Error codes are displayed on front panel LCD.

Error	Scope	Description	Corrective Action
101	Charger Module	<b>Invalid charger position jumper setting</b> for a charger module used in a multi-module unit. Jumpers must identify the module position: either no jumper (position 0) or a single jumper in positions 1 - 9. Not compatible with jumper-selected output settings for stand-alone chargers.	<ul style="list-style-type: none"> <li>- When a charger contains multiple charger modules, each module in that unit must be set to a different position number. Install one jumper per module to select module positions 1 - 9, or no jumper to select position 0.</li> <li>- To operate without multiple outputs, use the keypad "DC Output #" selection in the "Other Settings" menu or the setup utility to disable all outputs. Then use the "Set Output" setting in the "Other Settings" menu or the setup utility to assign all modules to the "Default" DC output.</li> </ul>
102	Stand-alone Charger	<b>Simultaneous use of output jumper settings and keypad control</b> on a charger not used as a module. The keypad is enabled while the charger output is controlled by its jumper settings. Output can be either keypad controlled or jumper-selected, but not both simultaneously. Chargers not used as modules do not use jumpers to identify their installation positions.	<ul style="list-style-type: none"> <li>- To operate under keypad control, remove all charger output setting jumpers.</li> <li>- To disable keypad control, Change the "UI Access Level" setting in the "Service Tools" menu to "Monitor Only." For factory default settings install jumpers on the charger in all three Float Voltage positions or two float settings plus one Range jumper. For other standard settings install three jumpers on the charger to select the Battery Type, Float Voltage, and Range for your battery.</li> </ul>
103	Stand-alone Charger	<b>Inconsistent jumper settings</b> for chargers not used as modules. When multiple stand-alone chargers operate in parallel using output jumper settings, all the chargers must have identical settings. This prevents unexpected output settings changes if the master charger (the charger with the lowest power board serial number) loses SENSbus data communication for any reason.	<ul style="list-style-type: none"> <li>- For factory default settings install jumpers on the charger in all three Float Voltage positions or two float settings plus one Range jumper of every charger.</li> <li>- For other standard settings, install three jumpers on each charger to select the Battery Type, Float Voltage and Range, using settings appropriate for your battery. All chargers must use the same settings.</li> <li>- For keypad control (programmed settings), remove all output setting jumpers from all the chargers.</li> </ul>
104	Charger Module	<b>Invalid output configuration.</b> Charger modules must be set to a valid output: either output A through D for use in multiple output units or 0 for use in single output units. Combining charger modules configured for use in single output units with those configured for multiple output units in the same unit (or system) is <b>not</b> supported.	<ul style="list-style-type: none"> <li>- If necessary, enable the output using the keypad "DC Output #" selection in the "Other Settings" menu or the setup utility.</li> <li>- To select a different output, reassign the module to match its actual output connection using the "Set DC Output" setting in the "Other Settings" menu or by using the setup utility.</li> <li>- To operate without multiple outputs, use the keypad "DC Output #" selection in the "Other Settings" menu or the setup utility to disable all outputs. Then use the "Set DC Output" setting in the "Other Settings" menu or the setup utility to assign all modules to the "Default" DC output.</li> </ul>
105	Charger Module	<b>Duplicate charger location</b> settings within a unit with multiple charger modules, not using the default output. Every charger module must have a unique location setting. Duplication is allowed for modules in different units, <i>i.e.</i> with different "Unit Serial Numbers". Modules using the "default" output do not use charger positions.	<ul style="list-style-type: none"> <li>- Use a different position number (jumper setting) for each module in a multi-module unit. See Error Code 101 for more detail.</li> <li>- When replacing a charger in a multi-module unit, set the replacement charger for the same position as the module being removed.</li> <li>- To prevent confusion, the position jumper settings should agree with the position markings on labels, internal wiring, <i>etc.</i> (so the displayed module ID number will match its physical and electrical position).</li> </ul>
201	Charger (or system)	<b>No charger modules assigned</b> to output. Every enabled charger output must have at least one module assigned to it. When none is found, it is	<ul style="list-style-type: none"> <li>- Check for a module that has failed (indicated by its LED status).</li> <li>- Check for disconnected or damaged SENSbus data</li> </ul>

Error	Scope	Description	Corrective Action
		presumed that a module has failed, has lost SENSbus data communication, or has an incorrect output setting.	cables. - If the output is not to be used, disable it by using the keypad "DC Output #" setting in the "Other Settings" menu or the setup utility.
202	Charger (or system)	<b>Too few charger modules operating.</b> The combined output rating of all modules operating on this charger output is less than the rated output. This can occur because a module has failed, has an open AC input or DC output connection, has lost SENSbus data communication, or is configured for the wrong output.	<ul style="list-style-type: none"> <li>- Use the "Set DC Output" setting in the "Other Settings" menu or the setup utility to verify all chargers output settings. Each module must be set for the output corresponding to its electrical DC output connection.</li> <li>- If necessary, install additional modules to meet the required output rating (plus the additional modules needed for "N+1" or "N+2" redundant operation).</li> <li>- Verify that each output is assigned enough modules to meet the required DC output rating (plus any extra modules needed to provide "N+1" or "N+2" redundant operation).</li> <li>- Check for a module that has failed (indicated by its LED status).</li> <li>- Check for disconnected or damaged SENSbus data cables.</li> <li>- Check for miswired, disconnected, or damaged input and output connections.</li> </ul>
203	Charger (or system)	<b>Charger Module assigned to a disabled output.</b> All modules must either be set for single output operation (0, Default output) or to a valid output that is enabled in this unit or system.	<ul style="list-style-type: none"> <li>- To use this output, enable it using the keypad "DC Output #" selection in the "Other Settings" menu or the setup utility. Verify that the DC outputs of all modules assigned to each output are electrically connected to that output.</li> <li>- To select a different output, reassign the module to match its actual output connection using the "Set DC Output" setting in the "Other Settings" menu or by using the setup utility.</li> <li>- To operate without multiple outputs, use the keypad "DC Output #" selection in the "Other Settings" menu or the setup utility to disable all outputs. Then use the "Set DC Output" setting in the "Other Settings" menu or the setup utility to assign all chargers to the "Default" DC output .</li> </ul>
301	Charger (or system)	<b>Missing charger modules.</b> A module that should be present is missing, has failed, or is otherwise not found on the SENSbus network. The number of modules in this system must not be less than the "Minimum System Number of Chargers" setting. This setting defines how many modules should be installed, particularly in "N+1" and "N+2" redundant configurations (where full output is possible without all modules operating). This setting normally is 0 (Off) for non-redundant systems, which disables this error check.	<ul style="list-style-type: none"> <li>- Check for a module that has failed (indicated by its LED status).</li> <li>- Check for disconnected or damaged SENSbus data cables.</li> <li>- Use the "Minimum System Number of Chargers" selection in the "Other Settings" menu or the setup utility to verify the system charger count setting. For "N+1" or "N+2" redundant operation this should be the number of charger modules connected to the SENSbus network. Non-redundant systems normally use a 0 setting (which disables this error check), but may be set if error checking is desired.</li> </ul>

13.2. Troubleshooting

AC LED	DC LED	Symptom	Possible Causes	Recommended Actions
OFF	OFF	Both AC and DC LEDs are off on models <u>without accessory display board</u>	<ol style="list-style-type: none"> <li>1. Proper AC or DC voltages not applied</li> <li>2. Main power board frozen</li> <li>3. Main power board failure</li> </ol>	<ol style="list-style-type: none"> <li>1. Using a voltmeter, check that AC input voltage and frequency at AC input terminal block (J100) are in the range 80VAC – 265VAC / 47Hz – 63Hz or that &gt;8VDC is present at DC output terminal block (J800) and that the DC polarity is correct. Correct charger AC input and DC output voltage as required.</li> <li>2. If step 1 doesn't resolve issue, remove both AC and DC power for 1 minute, then reapply power.</li> <li>3. If steps 1 and 2 don't resolve issue, a main power board failure is the likely cause. Replace charger.</li> </ol>
OFF	OFF	Both AC and DC LEDs are off and <u>display is off</u>	<ol style="list-style-type: none"> <li>1. Proper AC or DC voltages not applied</li> <li>2. Frozen accessory display board or main power board</li> <li>3. Main power board to accessory display board cable is incorrectly installed</li> <li>4. Main power board to accessory board cable failure or poor connection</li> <li>5. Main power board failure</li> <li>6. Accessory display board failure</li> </ol>	<ol style="list-style-type: none"> <li>1. Using a voltmeter, check that AC input voltage and frequency at AC input terminal block (J100) are in the range 80VAC – 264VAC / 47Hz – 63Hz or that &gt;8VDC is present at DC output terminal block (J800) and that the DC polarity is correct. Correct charger AC input and DC output voltage as required.</li> <li>2. If step 1 doesn't resolve issue, remove both AC and DC power for 1 minute, then reapply power.</li> <li>3. If steps 1 and 2 don't resolve issue, determine if main power board AC and DC LEDs are on (any color). If main power board LEDs are off, remove cable between accessory display board and main power board. If main power board LEDs remain off, a main power board failure is the likely cause. Replace charger. If main power board LEDs are on, proceed to step 4.</li> <li>4. If step 3 doesn't resolve issue, check that the main power board to accessory display board cable is correctly installed between main power board J900 and accessory display board J1, and that both ends of the cable are fully inserted.</li> <li>5. If step 4 doesn't resolve issue, unplug the main power board to accessory display board cable and, using an ohmmeter, check for continuity across the cable on each pin of the cable (cable is a straight pass through). If an open connection is found, replace cable (208117). If cable ohms out ok, a failed accessory display board is the likely cause. Replace accessory display board.</li> </ol>
OFF	OFF	Both AC and DC LEDs are off and <u>display is on</u>	<ol style="list-style-type: none"> <li>1. Charger communication terminator is missing</li> <li>2. Failed main power board</li> <li>3. Jumper installed in address 1 or address 2 header on main power board</li> <li>4. Main power board to accessory display board cable failure</li> <li>5. Failed accessory display board</li> </ol>	<ol style="list-style-type: none"> <li>1. Verify that a terminator is installed in port 1 or 2 of main power board J901. If terminator is missing, install missing terminator.</li> <li>2. If terminator is installed, disconnect one end of the main power board to accessory display board cable. Verify that main power board AC and DC LEDs are on (any color). If main power board LEDs remain off, replace charger, main power board has most likely failed.</li> <li>3. If power board LEDs are on, make sure there are no jumpers installed in Address 1 or Address 2 on main power board header JP900. Remove any address jumpers.</li> <li>4. If step 3 doesn't resolve issue, unplug the main power board to accessory display board cable and, using an ohmmeter, check for continuity across the cable on each pin of the cable (cable is a straight pass through). If an open connection is found, replace cable (208117). If cable ohms out ok, a failed accessory display board is the likely cause. Replace accessory display board.</li> </ol>
*SOLID GREEN	FLASH LONG-SHORT GREEN	AC LED is green, DC LED flashes Long-Short green, and output voltage is lower than expected	<ol style="list-style-type: none"> <li>1. Charger is in HELIX Eco-Float mode</li> </ol>	<ol style="list-style-type: none"> <li>1. Output voltage is automatically lowered to extend battery life in the HELIX Eco-Float mode. Charger will automatically refresh the battery as required and no action is needed (this is normal operation). If a customer wishes to disable HELIX mode, use a</li> </ol>

AC LED	DC LED	Symptom	Possible Causes	Recommended Actions
				battery type other than FLA, disable it using the Setup Utility, or disable it via the option keypad.
*SOLID GREEN	FLASH LONG-SHORT-SHORT GREEN	AC LED is green, DC LED flashes Long-Short-Short green, and output voltage is higher than expected float voltage	1. Charger is in HELIX REFRESH mode	1. Charger will automatically refresh the battery as required and no action is needed (this is normal operation). If a customer wishes to disable HELIX mode, use a battery type other than FLA, disable it using the Setup Utility, or disable it via the option keypad.
*SOLID GREEN	FLASH or SOLID GREEN	Unable to Communicate using J1939 on models <u>without accessory display board</u>	1. Address jumper is not installed or is installed in the wrong position 2. No communication bus termination installed 3. Wiring is incorrect 4. Unsupported or incorrect J1939 command 5. Cannot find an available address on the network	1. Verify that a jumper is installed in Address 1 or Address 2 (depending on selected address) on main power board header JP900. Correct address jumper if missing, incorrect address, or if multiple addresses are selected. 2. If step 1 doesn't address the issue, verify that a terminator is installed in port 1 or 2 of main power board J901. If terminator is missing, install missing terminator. (Note that a terminator is not required if the charger is not at the end of the communication bus). 3. If a terminator is correctly installed, verify that cabling is correct and the J1939 Data High goes to pin 1 of J901 and that J1939 Data Low goes to pin 2 of J901. 4. If step 3 didn't resolve the issue, verify that requested command is supported by SENS charger per J1939 table in charger manual. 5. If the steps above didn't resolve the issue, check for address conflicts on the network
*SOLID GREEN	FLASH or SOLID GREEN	Unable to Communicate using J1939 on models <u>with accessory display board</u>	1. Address jumper is not installed or is installed in the wrong position 2. No communication bus termination installed 3. Communication cable is plugged into the wrong charger port 4. Wiring is incorrect 5. Unsupported or incorrect J1939 command 6. Incorrect address or address conflict	1. Verify that a jumper is installed in Battery Charger (BCH) 1 or Battery Charger (BCH) 2 (depending on selected address) on accessory display board header JP2. Correct address jumper if missing or incorrect address. 2. If a terminator is correctly installed, verify that a terminator is installed in port 1 or 2 of accessory display board J2. If terminator is missing, install missing terminator. (Note that a terminator is not required if the charger is not at the end of the communication bus). 3. If step 3 didn't resolve the issue, verify that communication cable is connected to port 1 or port 2 of J2 on the accessory display board. Correct cabling as required. 4. If communication cable is connected correctly, verify that cabling is correct and the J1939 Data High goes to pin 1 of J2 and that J1939 Data Low goes to pin 2 of J2. 5. If cable wiring is correct, verify that requested command is supported by SENS charger per J1939 table in charger manual. 6. Check for address conflicts on the network
*SOLID GREEN	FLASH or SOLID GREEN	Basic J1939 communications work but SENS extended commands don't work	1. SENS extended J1939 commands are not enabled	1. Enable SENS extended J1939 commands using setup utility
*SOLID GREEN	FLASH or SOLID GREEN	Unable to Communicate using MODBUS on models <u>without accessory display board</u>	1. No communication bus termination installed 2. Wiring is incorrect 3. Incorrect MODBUS settings (baud rate, type (RTU or ASCII), address)	1. Verify that a terminator is installed in port 1 or 2 of main power board J901. If terminator is missing, install missing terminator. (Note that a terminator is not required if the charger is not at the end of the communication bus). 2. If a terminator is installed, verify that cabling is correct and that Modbus +D1 (A) goes to pin 5 of J900 and that Modbus -DO (B) goes to pin 4 of J900. 3. If cable wiring is correct, verify that charger and application MODBUS settings are as required. Adjust settings using setup utility as required.
*SOLID	FLASH or	Unable to Communicate	1. No communication bus	1. Verify that a terminator is installed in port 1 or 2 of

AC LED	DC LED	Symptom	Possible Causes	Recommended Actions
GREEN	SOLID GREEN	using MODBUS on models <u>with accessory display board</u>	<ol style="list-style-type: none"> <li>1. termination installed</li> <li>2. Communication cable is plugged into the wrong charger port</li> <li>3. Wiring is incorrect</li> <li>4. Incorrect MODBUS settings (baud rate, type (RTU or ASCII), address)</li> </ol>	<ol style="list-style-type: none"> <li>1. accessory display board J2. If terminator is missing, install missing terminator. (Note that a terminator is not required if the charger is not at the end of the communication bus).</li> <li>2. If terminator is installed, verify that communication cable is connected to port 1 or port 2 of J2 on the accessory display board. Correct cabling as required.</li> <li>3. If cable is connected correctly, verify that cabling is correct and that Modbus +D1 (A) goes to pin 5 of J2 and that Modbus –D0 (B) goes to pin 4 of J2.</li> <li>4. If cable wiring is correct, verify that charger and application MODBUS settings are as required. Adjust settings using setup utility as required.</li> </ol>
*SOLID GREEN	SOLID RED	AC good, charger fail or overvoltage shutdown	<ol style="list-style-type: none"> <li>1. Charger has experienced an unexpected fault</li> <li>2. Programmed setting are incorrect (OVSD set too low)</li> <li>3. Power board failure</li> </ol>	<ol style="list-style-type: none"> <li>1. Remove both AC and DC power for 1 minute, then reapply power.</li> <li>2. If fault remains, check overvoltage shutdown settings and again remove both AC and DC power for 1 minute, then reapply power.</li> <li>3. If steps 1 and 2 don't resolve issue, a main power board failure is the likely cause. Replace charger.</li> </ol>
*SOLID GREEN	FLASHING RED/YELLOW	Charger's output is not enabled	<ol style="list-style-type: none"> <li>1. A battery is connected to the charger output with reverse polarity</li> </ol>	<ol style="list-style-type: none"> <li>1. Correct DC polarity applied to main power board DC output terminal block (J800).</li> </ol>
*SOLID GREEN	SOLID YELLOW	AC good, high battery voltage	<ol style="list-style-type: none"> <li>1. Alarm setpoint incorrect for application</li> <li>2. DC voltage is high due to an external source such as an alternator</li> </ol>	<ol style="list-style-type: none"> <li>1. Check that charger battery settings and alarms are set appropriately for the application and battery under charge.</li> <li>2. If settings and alarms are correct, check and correct battery / load voltage (consider battery surface charge, alternator, and any connected equipment).</li> </ol>
*SOLID GREEN	SOLID YELLOW	AC good, low battery voltage	<ol style="list-style-type: none"> <li>1. Alarm setpoint incorrect for application</li> <li>2. Battery discharged or defective</li> </ol>	<ol style="list-style-type: none"> <li>1. Check that charger battery settings and alarms are set appropriately for the application and battery under charge.</li> <li>2. If settings and alarms are correct, check and correct battery / load voltage (consider loads and any connected equipment).</li> </ol>
*SOLID GREEN	FLASHING GREEN/RED	AC good, system DC output good, some individual charger(s) in alarm state (For multi-charger system with optional accessory display circuit board only)	<ol style="list-style-type: none"> <li>1. One or more system chargers has an alarm.</li> </ol>	<ol style="list-style-type: none"> <li>1. Troubleshoot issue using fault code from individual chargers.</li> </ol>
*SOLID GREEN	FLASHING YELLOW	AC good, low incompatible battery error (charger disabled)	<ol style="list-style-type: none"> <li>1. Voltage range improperly set</li> </ol>	<ol style="list-style-type: none"> <li>1. Check that charger voltage range is set correctly for the battery. After making any correction to the range setting, remove both AC and DC power for 1 minute, then reapply power.</li> </ol>
*SOLID GREEN	FLASHING GREEN/YELLOW	AC good, output power limited	<ol style="list-style-type: none"> <li>1. Charger power is reduced to protect charger due to high temperatures</li> </ol>	<ol style="list-style-type: none"> <li>1. Reduce operating environment temperature. Charger will automatically increase power as temperature is lowered.</li> </ol>
*SOLID GREEN	DOUBLE FLASH YELLOW	AC good, load share fail	<ol style="list-style-type: none"> <li>1. Charger output settings do not match between chargers</li> </ol>	<ol style="list-style-type: none"> <li>1. Check that individual charger settings are identical. Adjust as required. After making any adjustments, unplug and re-plug SENSbus cable from charger.</li> </ol>
*SOLID GREEN	DOUBLE FLASH RED	AC good, output disabled	<ol style="list-style-type: none"> <li>1. Negative DC connection is broken to one of the chargers</li> <li>2. Too many devices on the SENSbus network</li> </ol>	<ol style="list-style-type: none"> <li>1. Check that the negative DC connection at main power board J800 is made and that connection is tight.</li> <li>2. If step 1 doesn't resolve issue, look for break in the DC ground cable.</li> <li>3. If steps 1 and 2 don't resolve the issue, ensure that less than 30 devices are on the SENSbus.</li> <li>4. If none of the above steps resolved the issue, a failed accessory display board is likely, replace accessory display board.</li> </ol>
SOLID RED	SOLID GREEN	AC fail, battery voltage good	<ol style="list-style-type: none"> <li>1. Proper AC voltages or frequency not applied</li> <li>2. Power board failure</li> </ol>	<ol style="list-style-type: none"> <li>1. Using a voltmeter, check that AC input voltage and frequency at AC input terminal block (J100) are in the range 80VAC – 264VAC / 47Hz – 63Hz. Correct charger AC input voltage as required</li> </ol>

AC LED	DC LED	Symptom	Possible Causes	Recommended Actions
				2. If step 1 doesn't resolve issue, a main power board failure is the likely cause. Replace charger.
SOLID RED	SOLID YELLOW	AC fail, high battery voltage	<ol style="list-style-type: none"> <li>1. Proper AC voltages or frequency not applied</li> <li>2. Main power board Failure</li> </ol> <p>And</p> <ol style="list-style-type: none"> <li>3. Alarm setpoint incorrect for application</li> <li>4. DC voltage is high due to an external source such as an alternator</li> </ol>	<p>AC LED</p> <ol style="list-style-type: none"> <li>1. Using a voltmeter, check that AC input voltage and frequency at AC input terminal block (J100) are in the range 80VAC – 264VAC / 47Hz – 63Hz or that &gt; 8VDC is present at DC output terminal block (J800) and that the DC polarity is correct. Correct charger AC input and DC output voltage as required.</li> <li>2. If step 1 doesn't resolve RED AC light, remove both AC and DC power for 1 minute, then reapply power.</li> <li>3. If steps 1 and 2 don't resolve RED AC light, a main power board failure is the likely cause. Replace charger.</li> </ol> <p>DC LED</p> <ol style="list-style-type: none"> <li>4. Check that charger battery settings and alarms are set appropriately for the application and battery under charge.</li> <li>5. If settings and alarms are correct, check and correct battery / load voltage (consider battery surface charge, alternator, and any connected equipment).</li> </ol>
SOLID RED	SOLID YELLOW	AC fail, low battery voltage	<ol style="list-style-type: none"> <li>1. Proper AC voltages or frequency not applied</li> <li>2. Main power board Failure</li> </ol> <p>And</p> <ol style="list-style-type: none"> <li>3. Alarm setpoint incorrect for application</li> <li>4. Battery discharged or defective</li> </ol>	<p>AC LED</p> <ol style="list-style-type: none"> <li>1. Using a voltmeter, check that AC input voltage and frequency at AC input terminal block (J100) are in the range 80VAC – 264VAC / 47Hz – 63Hz or that &gt; 8VDC is present at J800 and that the DC polarity is correct. Correct charger AC input and DC output voltage as required.</li> <li>2. If step 1 doesn't resolve RED AC light, remove both AC and DC power for 1 minute, then reapply power.</li> <li>3. If steps 1 and 2 don't resolve RED AC light, a power board failure is the likely cause. Replace charger.</li> </ol> <p>DC LED</p> <ol style="list-style-type: none"> <li>4. Check that charger battery settings and alarms are set appropriately for the application and battery under charge.</li> <li>5. If settings and alarms are correct, check and correct battery / load voltage (consider loads and any connected equipment).</li> <li>6. If fault remains after the above steps, check battery health. Replace battery if weak.</li> </ol>
SOLID RED	SOLID RED	AC fail, charger fail or overvoltage shutdown	<ol style="list-style-type: none"> <li>1. Charger is in a fault state</li> <li>2. Charger failure</li> </ol>	<p>AC LED</p> <ol style="list-style-type: none"> <li>1. Using a voltmeter, check that AC input voltage and frequency at AC input terminal block (J100) are in the range 80VAC – 264VAC / 47Hz – 63Hz or that &gt; 8VDC is present at J800 and that the DC polarity is correct. Correct charger AC input and DC output voltage as required.</li> <li>2. If step 1 doesn't resolve RED AC light, remove both AC and DC power for 1 minute, then reapply power.</li> <li>3. If steps 1 and 2 don't resolve RED AC light, a power board failure is the likely cause. Replace charger.</li> </ol> <p>DC LED</p> <ol style="list-style-type: none"> <li>4. Remove AC and DC power from charger for 1 minute before reapplying power. Ensure AC voltage and/or DC voltage is within specified operating limits of the charger.</li> <li>5. If fault remains, check overvoltage shutdown settings and again remove both AC and DC power for 1 minute, then reapply power.</li> <li>6. If steps 1 and 2 don't resolve issue, a power board</li> </ol>

AC LED	DC LED	Symptom	Possible Causes	Recommended Actions
				failure is the likely cause. Replace charger.
SOLID RED	FLASHING YELLOW	AC fail, low incompatible battery error	<ol style="list-style-type: none"> <li>1. Proper AC voltages or frequency not applied</li> <li>2. Main power board Failure</li> </ol> <p>And</p> <ol style="list-style-type: none"> <li>3. Voltage range improperly set</li> </ol>	<p>AC LED</p> <ol style="list-style-type: none"> <li>1. Using a voltmeter, check that AC input voltage and frequency at AC input terminal block (J100) are in the range 80VAC – 264VAC / 47Hz – 63Hz or that &gt; 8VDC is present at J800 and that the DC polarity is correct. Correct charger AC input and DC output voltage as required.</li> <li>2. If step 1 doesn't resolve RED AC light, remove both AC and DC power for 1 minute and then reapply power.</li> <li>3. If steps 1 and 2 don't resolve RED AC light, a main power board failure is the likely cause. Replace charger.</li> </ol> <p>DC LED</p> <ol style="list-style-type: none"> <li>4. Check that charger voltage range is set correctly for the battery. After making any correction to the range setting, remove both AC and DC power for 1 minute, then reapply power</li> </ol>
ALTERNATING FLASHING YELLOW		No output	<ol style="list-style-type: none"> <li>1. Illegal jumper or program configuration</li> </ol>	<ol style="list-style-type: none"> <li>1. If in factory mode, make sure all three float position have a jumper or that 2 of 3 float positions have a jumper and that the third jumper is placed in the 12 or 24 volt range position. Remove any addition battery type or range jumpers.</li> <li>2. If using standard jumper configuration, ensure a single jumper is placed in battery type, float, and range.</li> <li>3. If in program mode, ensure that charger has been programmed to desired settings (program mode is set from the factory to have no output).</li> </ol>
ALTERNATING FLASHING RED		No output	<ol style="list-style-type: none"> <li>1. Missing or invalid code (boot load required)</li> </ol>	<ol style="list-style-type: none"> <li>1. Update charger firmware using setup utility.</li> <li>2. If steps 1 doesn't resolve issue or setup utility is not available, replace charger</li> </ol>
ALTERNATING FLASHING GREEN		For chargers with optional alarm/communications circuit board only: Starting-up	<ol style="list-style-type: none"> <li>1. Charger is still powering-on</li> <li>2. Failed accessory display board</li> </ol>	<ol style="list-style-type: none"> <li>1. Remove both AC and DC power for 1 minute and then reapply power. Allow charger at least 1 minute to fully boot.</li> <li>2. If step 1 doesn't resolve issue, an accessory display board failure is the likely cause. Replace accessory display board.</li> </ol>

\*AC LED will flash green when charger is in ultracapacitor mode.



**14 GLOSSARY**

---

Original Factory Configuration	Configuration set at the factory. Charger operates using settings configured at the factory per customer order. Indicated by three jumpers in the three FLOAT jumper positions on the main circuit board.
Standard Jumper Configuration	Charger operates according to main circuit board jumpers rather than original factory configuration. Indicated by one jumper each in BATTERY TYPE, FLOAT and RANGE positions.
Battery Type	Indicates the type of battery being charged. Battery type is selected when ordering charger for original factory configuration or by jumper position if using standard jumper configuration.
Range	RANGE is a jumper position on the main circuit board set when using standard jumper configuration. Indicates system DC output voltage, 12 volts or 24 volts.
Program Mode	In Program Mode, charger output is determined by values programmed in the charger using computer to charger cable (SENSbus adapter) and SENS Setup Utility Kit (SENS p/n 209254 plus SENS software available at <a href="http://www.sens-usa.com">www.sens-usa.com</a> ). Removing all jumpers from the BATTERY TYPE, FLOAT and RANGE positions enables Program Mode.
Configuration Code	Indicates charger output voltage configuration. Configuration code is included on nameplate label on open-frame chargers and on inside cover label on enclosed chargers.
SAE J1939 (CANbus)	J1939 is a communications protocol provided by SAE International and used in the commercial vehicle area for communication between the charger and genset controller.
Modbus	Modbus is an application layer messaging protocol provided by Modbus Organization and used for client/server communication.

# ENCLOSED CHARGER

DCN		REV		REVISIONS		DATE	APPROVED
107038	A	INITIAL RELEASE		6/23/2014	JWF		
107141	B	UPDATE VIEWS AND MOUNTING DIMENSIONS		10/31/2014	JWF		
107158	C	UPDATE VIEWS AND CALLOUTS		12/19/2016	JWF		

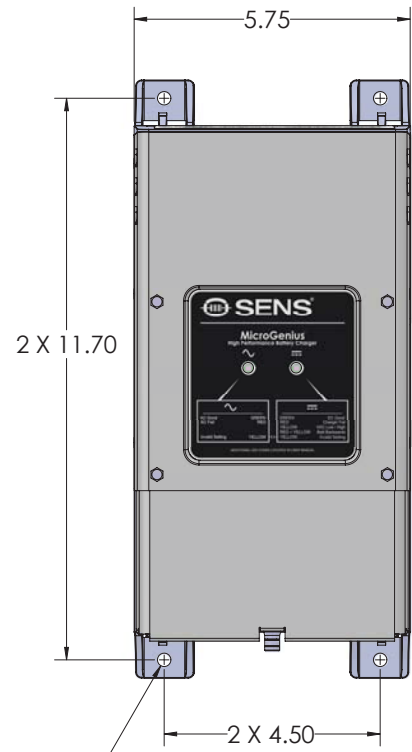
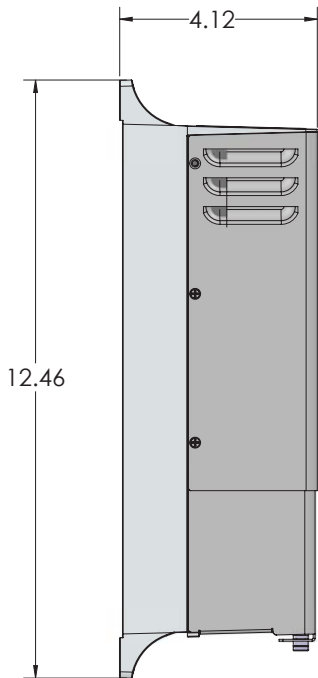

**FRONT VIEW  
NO DISPLAY**



**FRONT VIEW  
WITH OPTIONAL  
DISPLAY**



**FRONT VIEW  
WITH OPTIONAL  
DISPLAY AND  
OPTIONAL KEYPAD**

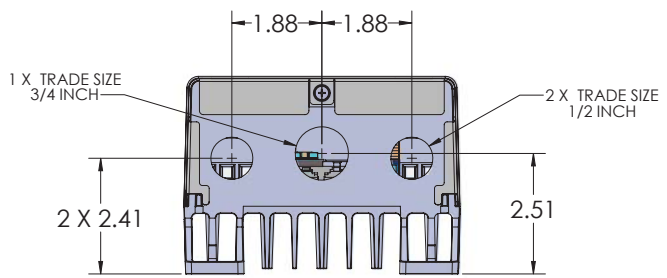

<p><b>SENS</b> STORED ENERGY SYSTEMS</p> <p>PROPRIETARY AND CONFIDENTIAL</p> <p>THE INFORMATION CONTAINED IN THIS DRAWING IS THE SOLE PROPERTY OF STORED ENERGY SYSTEMS, LLC. ANY REPRODUCTION IN PART OR AS A WHOLE WITHOUT THE WRITTEN PERMISSION OF STORED ENERGY SYSTEMS, LLC, IS PROHIBITED.</p>	UNLESS OTHERWISE SPECIFIED: DIMENSIONS ARE IN INCHES DEFAULT TOLERANCES:	NAME	DATE	DESCRIPTION		
	DO NOT SCALE DRAWING	DRAWN	JWF	2/7/2014	2DCAD, MG2, ENCLOSED, STANDARD	
		CHECKED				
		THIRD ANGLE PROJECTION		SIZE	DOCUMENT NUMBER	REV
		<p>DIMENSIONS &amp; TOLERANCES PER ASME Y14.5 - 2009</p>		<b>C</b>	2DCAD-MG2-STD-ENC	<b>C</b>
						SHEET 1 OF 2

**MOUNT  
THIS END UP  
(SEE NOTE 3)**

# ENCLOSED CHARGER CUSTOMER INSTALLATION

REVISIONS				
DCN	REV	DESCRIPTION	DATE	APPROVED
--	--	See sheet 1.	--	--

J1939 ADDRESS SELECT JUMPERS  
 J1939 OR MODBUS  
 REMOTE TEMPERATURE SENSOR CONNECTIONS (OPTIONAL)  
 ALARM CONNECTIONS  
 ALARM CONNECTIONS (OPTIONAL)

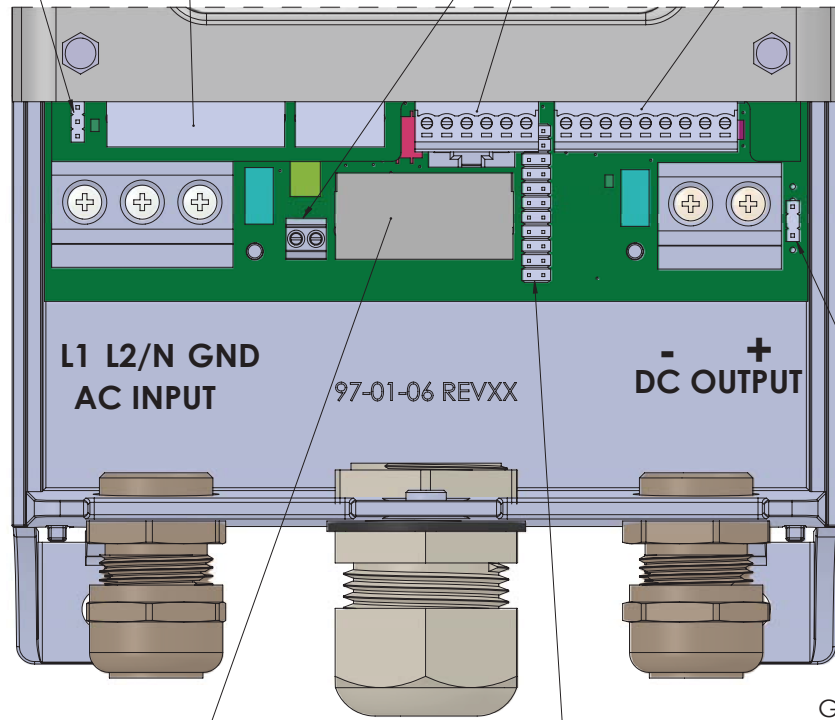

AC WIRING ENTRY  
 CONTROL WIRING ENTRY  
 DC WIRING ENTRY

**LOWER COVER  
REMOVED**

USER COMMUNICATIONS (MODEL DEPENDENT)  
 ACCESSORY BOARD (OPTIONAL)  
 CUSTOMER SUPPLIED CONDUIT OR CORD BUSHINGS

CHARGER OUTPUT JUMPER SETTINGS

GROUND FAULT JUMPER

- NOTES:
1. INSTALL ENCLOSED CHARGER USING CUSTOMER SUPPLIED 1/4 MAX MOUNTING HARDWARE.
  2. PROVIDE ADEQUATE CLEARANCE AROUND THE CHARGER FOR VENTILATION. MINIMUM CLEARANCES ARE: 0.5 INCHES FOR EACH SIDE, 4 INCHES AT BOTTOM SURFACE AND 6 INCHES ABOVE THE TOP SURFACE.
  3. CHARGER MUST BE MOUNTED VERTICALLY FOR ADEQUATE VENTILATION.

<p><b>SENS</b> STORED ENERGY SYSTEMS</p> <p>PROPRIETARY AND CONFIDENTIAL</p> <p>THE INFORMATION CONTAINED IN THIS DRAWING IS THE SOLE PROPERTY OF STORED ENERGY SYSTEMS, LLC. ANY REPRODUCTION IN PART OR AS A WHOLE WITHOUT THE WRITTEN PERMISSION OF STORED ENERGY SYSTEMS, LLC, IS PROHIBITED.</p>	UNLESS OTHERWISE SPECIFIED: DIMENSIONS ARE IN INCHES DEFAULT TOLERANCES:	NAME DATE	DESCRIPTION	
		DRAWN CHECKED	JWF 2/7/2014	2DCAD, MG2, ENCLOSED, STANDARD
		THIRD ANGLE PROJECTION DIMENSIONS & TOLERANCES PER ASME Y14.5 - 2009		SIZE DOCUMENT NUMBER REV
DO NOT SCALE DRAWING			C 2DCAD-MG2-STD-ENC C	
			SHEET 2 OF 2	

DCN		REV		REVISIONS		DATE	APPROVED
107158		A		INITIAL RELEASE		12/5/2016	ERS

# OPEN FRAME CHARGER

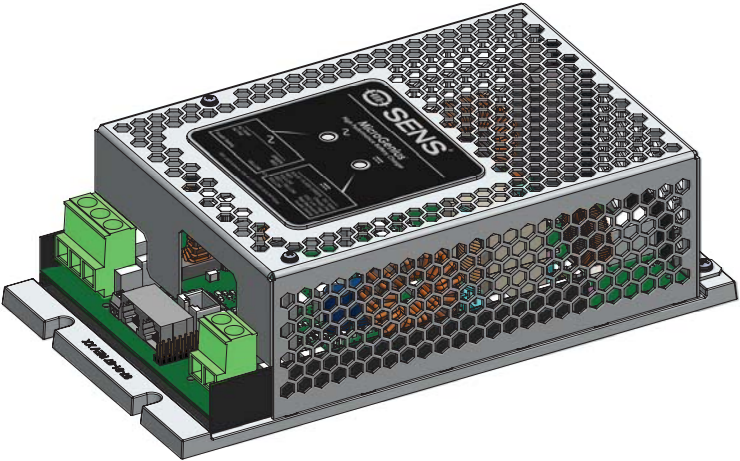
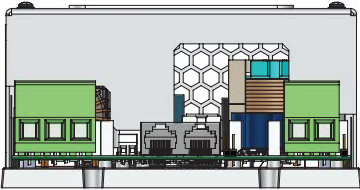
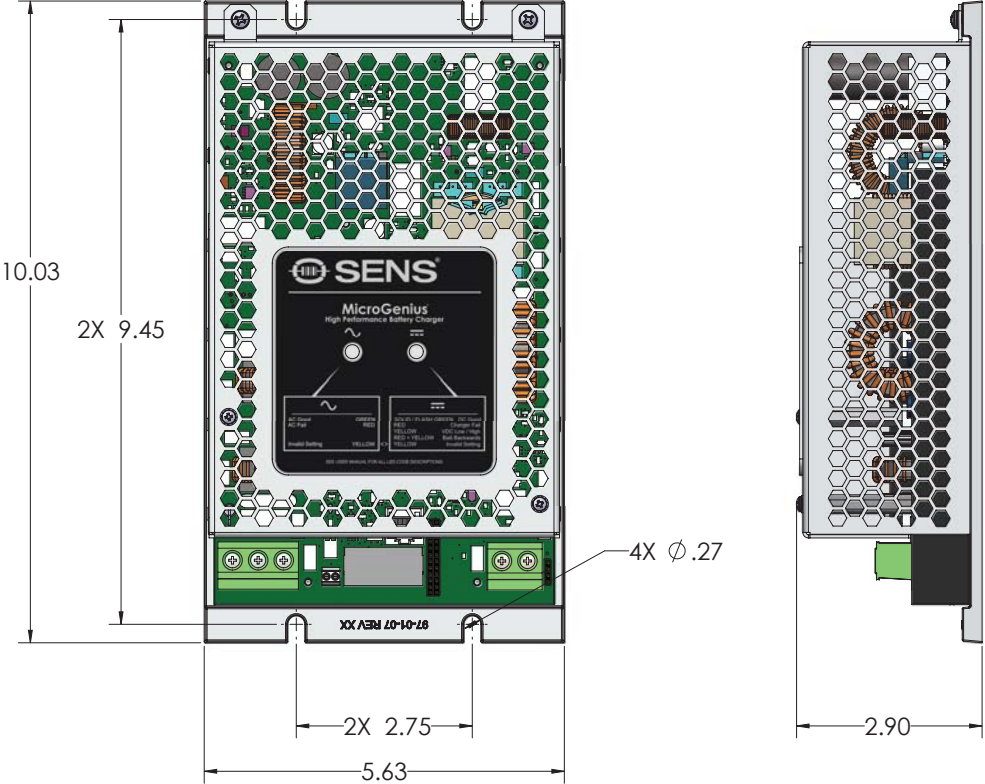

<p><b>SENS</b> STORED ENERGY SYSTEMS</p> <p>PROPRIETARY AND CONFIDENTIAL</p> <p>THE INFORMATION CONTAINED IN THIS DRAWING IS THE SOLE PROPERTY OF STORED ENERGY SYSTEMS, LLC. ANY REPRODUCTION IN PART OR AS A WHOLE WITHOUT THE WRITTEN PERMISSION OF STORED ENERGY SYSTEMS, LLC, IS PROHIBITED.</p>	UNLESS OTHERWISE SPECIFIED: DIMENSIONS ARE IN <b>INCHES</b> DEFAULT TOLERANCES:	NAME	DATE	DESCRIPTION	SIZE	DOCUMENT NUMBER	REV	
	DO NOT SCALE DRAWING	DRAWN	ERS	12/5/2016	<b>C</b>	2DCAD-MG2-STD-OPN	<b>A</b>	
		CHECKED						
		THIRD ANGLE PROJECTION						SHEET 1 OF 2

# OPEN FRAME CHARGER CUSTOMER INSTALLATION

REVISIONS				
DCN	REV	DESCRIPTION	DATE	APPROVED
--	--	See sheet 1.	--	--

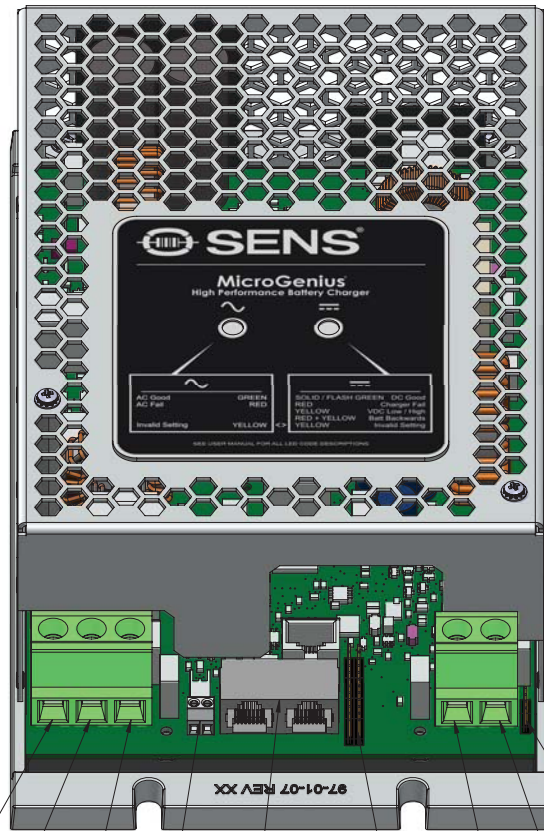

- AC L1
- AC L2/N
- GROUND
- REMOTE TEMPERATURE SENSE (OPTIONAL)
- USER COMMUNICATIONS
- GROUND FAULT JUMPER
- DC+
- DC -
- CHARGER OUTPUT JUMPER SETTINGS

- NOTES:
- INSTALL CHARGER USING CUSTOMER SUPPLIED 1/4 MAX MOUNTING HARDWARE.
  - HEAT SINK CHARGER TO A METAL SURFACE

<p><b>SENS</b> STORED ENERGY SYSTEMS</p> <p>PROPRIETARY AND CONFIDENTIAL</p> <p>THE INFORMATION CONTAINED IN THIS DRAWING IS THE SOLE PROPERTY OF STORED ENERGY SYSTEMS, LLC. ANY REPRODUCTION IN PART OR AS A WHOLE WITHOUT THE WRITTEN PERMISSION OF STORED ENERGY SYSTEMS, LLC, IS PROHIBITED.</p>	UNLESS OTHERWISE SPECIFIED: DIMENSIONS ARE IN INCHES DEFAULT TOLERANCES:	<table border="1"> <tr> <th>NAME</th> <th>DATE</th> <th>DESCRIPTION</th> </tr> <tr> <td>ERS</td> <td>12/5/2016</td> <td>2DCAD, MG2, OPEN-FRAME, STANDARD</td> </tr> </table>	NAME	DATE	DESCRIPTION	ERS	12/5/2016	2DCAD, MG2, OPEN-FRAME, STANDARD	
	NAME	DATE	DESCRIPTION						
	ERS	12/5/2016	2DCAD, MG2, OPEN-FRAME, STANDARD						
DO NOT SCALE DRAWING	<table border="1"> <tr> <th>THIRD ANGLE PROJECTION</th> <th>SIZE</th> <th>DOCUMENT NUMBER</th> <th>REV</th> </tr> <tr> <td></td> <td>C</td> <td>2DCAD-MG2-STD-OPN</td> <td>A</td> </tr> </table>	THIRD ANGLE PROJECTION	SIZE	DOCUMENT NUMBER	REV		C	2DCAD-MG2-STD-OPN	A
THIRD ANGLE PROJECTION	SIZE	DOCUMENT NUMBER	REV						
	C	2DCAD-MG2-STD-OPN	A						
			SHEET 2 OF 2						

### REMOTE PANEL WITH JUNCTION BOX

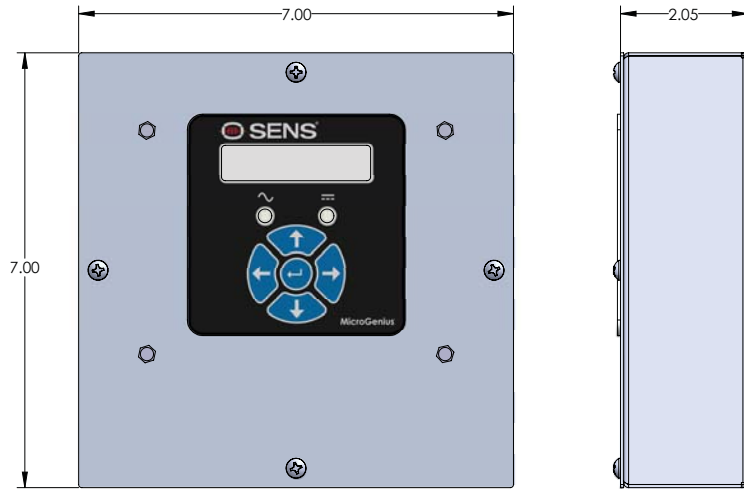

### REMOTE PANEL WITHOUT JUNCTION BOX

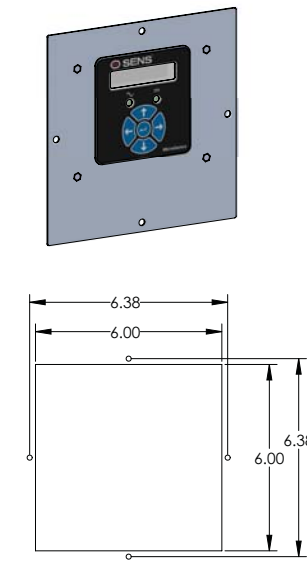
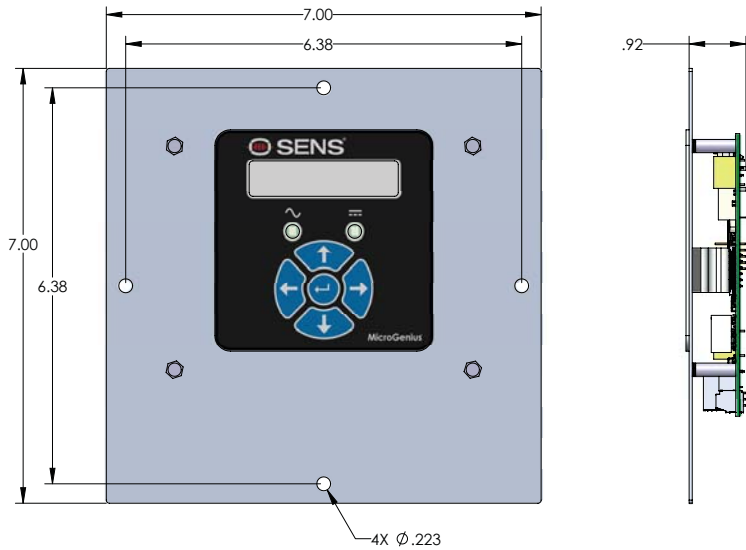

REMOTE PANEL CUTOUT DIMENSIONS

REVISIONS				
DCN	REV	DESCRIPTION	DATE	APPROVED
107320	A	INITIAL RELEASE	7/13/2017	SC
107318	B	NOMENCLATURE UPDATE	8/9/2017	SC

### REMOTE PANEL WIRING CONNECTIONS

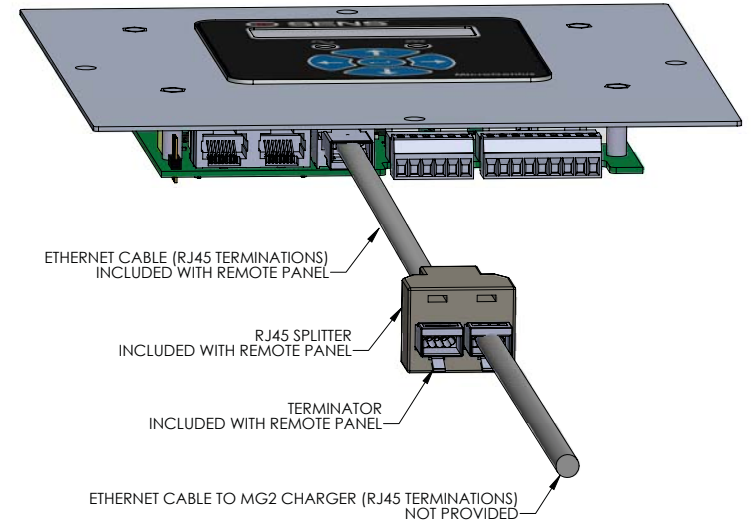

NOTE - MG2 CHARGER MUST HAVE TERMINATOR INSTALLED. TERMINATOR IS INCLUDED WITH REMOTE PANEL.



SENS  
 BEYOND ENERGY SYSTEMS  
 1440 HERRING GULL  
 COASTAL COURT  
 SUITE 100  
 WWW.SENS-SEA.COM  
 THE INFORMATION CONTAINED IN THIS DRAWING IS THE SOLE  
 PROPERTY OF SENS ENERGY SYSTEMS, LLC. ANY  
 REPRODUCTION, STORAGE, OR USE, WITHOUT THE WRITTEN  
 PERMISSION OF SENS ENERGY SYSTEMS, LLC, IS PROHIBITED.

UNLESS OTHERWISE SPECIFIED:  
 DIMENSIONS ARE IN INCHES  
 DEFAULT TOLERANCES:  
 FINISHES: 1/4"  
 TWO PLACE DECIMAL ± .03  
 THREE PLACE DECIMAL ± .005  
 DO NOT SCALE DRAWING

DATE	NAME	DESCRIPTION
7/13/2017	ESS	2DCAD, MG2, REMOTE PANEL

DATE	NAME	DESCRIPTION
7/13/2017	ESS	2DCAD, MG2, REMOTE PANEL

THIRD ANGLE PROJECTION	SIZE	DOCUMENT NUMBER	REV
	D	2DCAD-MG2-REMOTEPANEL-STD	B





## ***Confirmation of Product Type Approval***

Please refer to the "Service Restrictions" shown below to determine if Unit Certification is required for this product. This certificate reflects the information on the product in the ABS Records as of the date and time the certificate is printed.

Pursuant to the Rules of the American Bureau of Shipping (ABS), the manufacturer of the below listed product held a valid Manufacturing Assessment (MA) with expiration date of 30/MAY/2018. The continued validity of the Manufacturing Assessment is dependent on completion of satisfactory audits as required by the ABS Rules.

And; a Product Design Assessment (PDA) valid until 31/OCT/2021 subject to continued compliance with the Rules or standards used in the evaluation of the product.

The above entitle the product to be called Product Type Approved.

The Product Design Assessment is valid for products intended for use on ABS classed vessels, MODUs or facilities which are in existence or under contract for construction on the date of the ABS Rules used to evaluate the Product.

ABS makes no representations regarding Type Approval of the Product for use on vessels, MODUs or facilities built after the date of the ABS Rules used for this evaluation.

Due to wide variety of specifications used in the products ABS has evaluated for Type Approval, it is part of our contract that; whether the standard is an ABS Rule or a non-ABS Rule, the Client has full responsibility for continued compliance with the standard.

**Product Name: Battery Charger**  
**Model Name(s): MicroGenius 2**

**Presented to:**

STORED ENERGY SYSTEMS, LLC  
1840 INDUSTRIAL CIRCLE  
United States

**Intended Service:** Marine and Offshore Applications

**Description:** MicroGenius 2: Switchmode, regulated, filtered, microprocessor-controlled, current limited battery charger designed for heavy-duty industrial service. Primary application: quick recharge and long-life maintenance of engine start batteries and ultracapacitors. Refer to the attached sheet for Model Series Designation.

**Ratings:** Output Voltage: 12 or 24 VDC Nominal; Output Power: 180 W, 300W, or 450W  
Input Voltage: 100-240VAC Input Frequency: 50/60 Hz; Operational temperature at full rated output: -40 °C to +55 °C for 180W; -40 °C to +50 °C for 300W; -40°C to +40°C for 450W Enclosure: IP 22 aluminum/stainless steel enclosure;

**Service Restrictions:** Unit Certification is not required for this product. If the manufacturer or purchaser request an ABS Certificate for compliance with a specification or standard, the specification or standard, including inspection standards and tolerances, must be clearly defined. Not suitable for installation in hazardous areas.

**Comments:** The Manufacturer has provided a declaration about the control of, or the lack of Asbestos in this product. 1. End user must use output cables that have sufficient current carrying capacity as per ABS Steel Vessel Rules 4-8-2/7.7.1.

**Notes / Documentation:** Drawing No. COMPLIANCE SPEC, MicroGenius 2, Pages: 7 Drawing No. 2DCAD-MG2-STD-ENC, Charger drawing, Revision: B, Pages: 2 Drawing No. Alarm list, ABS alarm reqs mapped to MG2 charger, Pages: 1 Drawing No. MG2\_ABS\_Discharge\_2016-09-09, Charge curves, Pages: 89 Drawing No.

MG2\_ABS\_Recharge\_2016-09-09, MG2\_ABS\_Recharge\_2016-09-09, Pages: 71 Drawing No. MicroGenius\_2\_Model\_Designation, Pages: 1 Drawing No. SENS IP 22 Test, SENS IP 22 Test Report, Pages: 10 Drawing No. UL File E109740 Project 4787560097, UL\_Reverse\_Polarity\_Test, Pages: 1 Drawing No. UL Project 4787560097, SENS UL NofA-4787560097-Sep-20-2016, Pages: 1 Drawing No. EMI Test Lab LLC EMC Test Report, Revision: 1.0, Pages 65. Drawing No. ISO\_Platinum\_Cert\_2008\_RevD, ISO\_Platinum\_Cert\_2008\_RevD, Pages: 1 Drawing No. ISO\_SENS RA Report, ISO\_SENS RA Report, Pages: 1 Drawing No. 2016\_ABS\_Certificate\_Manufacturing\_Assessment, Pages: 1

**Term of Validity:**

This Product Design Assessment (PDA) Certificate 16-HS1570634-PDA, dated 01/Nov/2016 remains valid until 31/Oct/2021 or until the Rules or specifications used in the assessment are revised (whichever occurs first). This PDA is intended for a product to be installed on an ABS classed vessel, MODU or facility which is in existence or under contract for construction on the date of the ABS Rules or specifications used to evaluate the Product. Use of the Product on an ABS classed vessel, MODU or facility which is contracted after the validity date of the ABS Rules and specifications used to evaluate the Product, will require re-evaluation of the PDA. Use of the Product for non ABS classed vessels, MODUs or facilities is to be to an agreement between the manufacturer and intended client.

**ABS Rules:**

The Rules for Conditions of Classification, Part 1 2016 Steel Vessels Rules 1-1-4/7.7, 1-1-A3, 1-1-A4, which covers the following: 2016 Steel Vessel Rules: 4-8-3/1.11.1, 4-8-3/5.9; 2016 Offshore Support Vessels Rules: 4-8-3/1.11.1, 4-8-3/5.9; 2016 Steel Vessels Under 90M length: 4-6-3/3.1.3(a), 4-6-4/7.19. The Rules for Conditions of Classification, Part 1 2016 Offshore Units and Structures 1-1-4/9.7, 1-1-A2, 1-1-A3, which covers the following: 2016 Mobile Offshore Drilling Unit Rules: 4-3-3/3.1.1(a), 6-1-7/9.17.

**National Standards:**

UL 1236 Battery Chargers for Charging Engine-Starter Batteries, Edition 8 (UL File E109740 and EX6409).

**International Standards:**

CSA 22.2 No. 107.2 (2011), Battery Chargers (UL File E109740); IEC 60529 Degrees of Protection Provided by Enclosures (IP Code), 1989+A1:1999; EN 61000-6-4: 2007+A1:2011 Electromagnetic compatibility (EMC). Generic standards; EN 61000-6-2: 2005 Electromagnetic compatibility (EMC). Generic standards. Immunity for industrial environments.

**Government Authority:**

**EUMED:**

**Others:**

Model Certificate	Model Certificate No	Issue Date	Expiry Date
PDA	16-HS1570634-PDA	01/NOV/2016	31/OCT/2021



ABS Programs

ABS has used due diligence in the preparation of this certificate and it represents the information on the product in the ABS Records as of the date and time the certificate was printed. Type Approval requires Drawing Assessment, Prototype Testing and assessment of the manufacturer's quality assurance and quality control arrangements. Limited circumstances may allow only Prototype Testing to satisfy Type Approval. The approvals of Drawings and Products remain valid as long as the ABS Rule, to which they were assessed, remains valid. ABS cautions manufacturers to review and maintain compliance with all other specifications to which the product may have been assessed. Further, unless it is specifically indicated in the description of the product; Type Approval does not necessarily waive witnessed inspection or survey procedures (where otherwise required) for products to be used in a vessel, MODU or facility intended to be ABS classed or that is presently in class with ABS. Questions regarding the validity of ABS Rules or the need for supplemental testing or inspection of such products should, in all cases, be addressed to ABS.



**EC Declaration of Conformity**  
In accordance with EN ISO 17050-1:2004

Manufacturer:	Stored Energy Systems
Manufacture Address:	1840 Industrial Circle Longmont, CO 80501 U.S.A.
Product Type:	MicroGenius 2 Battery Charger
Model Numbers:	MX-YY-YYYY-YY, where X = 1, 3, 4, F, G, H; Y = any digit;
Conformance to Directives:	<p>Directive 2014/30/EU of the European Parliament and of the Council of 26 February 2014 on the harmonisation of the laws of the Member States relating to electromagnetic compatibility (recast)</p> <p>Directive 2014/35/EU of the European Parliament and of the Council of 26 February 2014 on the harmonisation of the laws of the Member States relating to the making available on the market of electrical equipment designed for use within certain voltage limits (recast)</p> <p>Directive 2011/65/EU of the European Parliament and of the Council of 8 June 2011 on the restriction of the use of certain hazardous substances in electrical and electronic equipment (recast)</p>
Harmonized and/or technical specifications applied in full:	<p>Directive 2014/30/EU (EMC) EN 61000-6-2:2005/AC:2005 EN 61000-6-4:2007/A1:2011 – Class B</p> <p>Directive 2014/35/EU (LVD) EN 60335-1:2012/A11:2014 EN 60335-2-29:2004/A2:2010</p> <p>Directive 2011/65/EU (RoHS (recast)) EN 63000:2018</p>
Place and date of first issue:	Longmont, CO USA on October 20, 2016

Under the sole responsibility of Stored Energy Systems, the undersigned hereby declares that the equipment specified above conforms to the essential requirements of the above Directives(s) and Standard(s).

  
\_\_\_\_\_  
Sam Coleman  
Compliance Manager  
Stored Energy Systems, LLC

6/7/2019  
\_\_\_\_\_  
Date



## **SENS Limited Warranty: NRG and MicroGenius<sup>®</sup> Battery Chargers**

### **What is covered?**

This warranty covers any defect in material and workmanship on NRG and MicroGenius battery chargers manufactured by Stored Energy Systems, a Colorado Limited Liability Company (SENS).

### **What this warranty does not cover:**

This warranty does not cover damages, defects or failures of your equipment resulting from shipping damage, accidents, installation errors, unauthorized adjustment or repair, unauthorized third-party service, failure to follow instructions, misuse, fire, flood, electrical transients, acts of persons not in our control, and acts of God.

### **For how long:**

MicroGenius 2, S2, NRG: Three (3) years from date of shipment, except magnetic parts and power semiconductors in NRG battery chargers, which are covered for 10 years. MicroGenius S4: Five (5) years from date of shipment.

### **What we will do:**

If your battery charger is defective within the warranty period, we will repair it or, at our option, replace it at no charge to you.

If we choose to replace your charger, we may replace it with a new or refurbished one of the same or similar design. The repair or replacement will be warranted for the remainder of the original warranty period. If we determine that your charger cannot be repaired or replaced, we will refund its purchase price to you.

### **What we ask you to do:**

Contact SENS service department to obtain warranty service instructions. To obtain warranty service the product must be returned, freight prepaid, to the factory under a Return Material Authorization (RMA) number provided by SENS. If, in SENS' opinion, the problem can be rectified in the field, SENS may elect to ship replacement parts for customer installation instead of having the product returned to the factory.

### **Limitation:**

This warranty is limited to defects in material or workmanship of the product. It does not cover replacement of consumables such as surge protective devices, unless defective. It does not cover loss of time, inconvenience, property damage or any consequential damages. Repair, replacement or refund of the purchase price of the equipment is your exclusive remedy.

## **Extended Warranty: NRG and MicroGenius Battery Chargers**

### **Extended Warranty Period**

At any time during the standard Limited Warranty period, customer may purchase extended warranty to lengthen the warranty period to 5 or 10 years from date of original shipment. All other terms of SENS Limited Warranty (see above) apply.

## **Premium Warranty: NRG and MicroGenius Battery Chargers**

### **Premium Warranty Coverage**

At the time of original purchase, customer may purchase premium warranty coverage for the standard warranty period. With premium warranty coverage, SENS will, if requested by customer, pay reasonable and customary labor and mileage charges for replacement or repair of the charger, limited to 100% of the original net product invoice amount, in the form of a credit toward future purchases from SENS. Premium warranty service is available only to the original customer who purchased the product from SENS; it does not pass through to other distributors, dealers or users. All other terms of SENS Limited Warranty (see above) apply.